

## **WIRELESS NETWORK CODING ON IMAGE PROCESSING AND ITS MAJOR APPLICATIONS: A STUDY**

**Sheily Verma<sup>1</sup>, Dr. Rashi Agarwal<sup>2</sup>**

**Department of Computer Science & Engineering**

**<sup>1,2</sup>Shri Venkateshwara University, Gajraula (Uttar Pradesh)**

### *Abstract*

This research gives a general depiction of how researchers utilized the essential idea of network coding in a few potential approaches to improve the performance of wireless networks. The parameters of performance, delay, bundle conveyance report, jitter, and so forth. Wireless networks are framed when gadgets associate with different gadgets through electromagnetic energy noticeable all around and start their communication utilizing radio waves. These networks can be grouped into networks dependent on infrastructures and specially appointed networks. Infrastructure-put together networks depend with respect to an access point for every one of their communications, while specially appointed networks are self-sorted out networks. A wireless sensor network (WSN) incorporates base stations and some wireless sensors (nodes). The WSNs are extraordinarily assigned networks (wireless nodes that self-sort out in an infrastructure without a network). Wireless sensor networks are commonly relevant to numerous cutting-edge military or mechanical applications, including normal checking, perception, challenge observing or wellbeing checking.

### **1. OVERVIEW**

In the execution of the utilizations of the wireless sensor network of the factory, the utilization of energy is the most key factor, since the nodes of the sensors have an amazingly constrained hold of energy and are important to operate independently. His primary idea relies upon the dispersion of the remaining task at hand of processing wavelet changes between various nodes. Two strategies for data exchanging have been proposed. Along these lines, broad research has concentrated on the most able technique to constrain energy use and broaden the helpful existence of the network. In this procedure, we consider the data dissemination plan proposed utilizing LS 9/7 DWT[1].

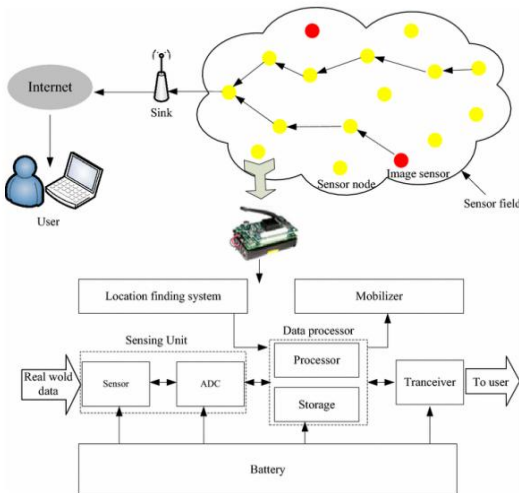

Figure 1: Sensor Network Architecture

It is believed that a routing algorithm is configured and that the nodes organize themselves in a two-level design. The research shows that SS is the only algorithm that presents the energy funds in the absence of pressure, which allows a decrease in power of about 29% of the proposed mechanism [2]. This father-young relationship is made to reinforce SPIHT fragilities in case of transmission of bit errors.

The pressure of the circulated image is taken into consideration for the images captured by the sensor nodes that have fields of vision. The approach uses a strategy such as the pressure of the stereo image to distinguish coverage in the images of adjacent sensor nodes. The image is the most important vector between the intercommunication of information in people's lives and the most important media that contain information.

## 2. IMAGE PROCESSING

Image processing is a technique for changing an image into a computerized structure and playing out certain tasks on it, considering a definitive objective of acquiring an improved image or expelling some significant data from it. It is a kind of banner harmony where the info is an image, like the edge of the video or photograph and the performance can be the image or characteristics identified with that image.

As a rule, the image processing system fuses images as two-dimensional signs by applying authoritatively settled banner processing techniques. Today it is one of the most quickly advancing technologies, with its applications in various pieces of an organization. The image processing systems center the research region inside the development and data trains.

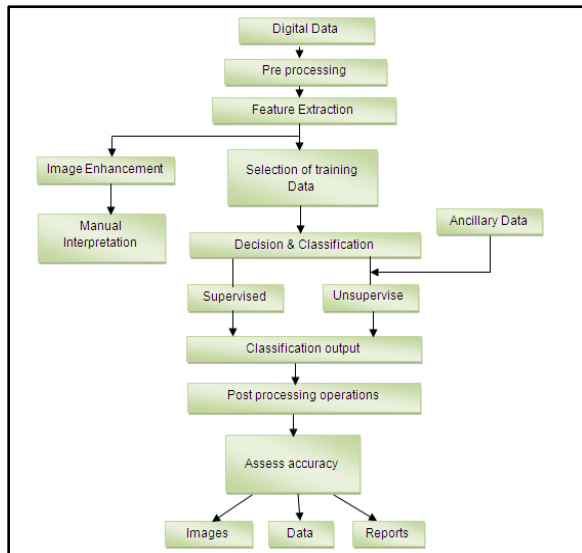

**Figure 2: Image processing**

The two kinds of strategies utilized for image processing are simple and digital image processing. Straightforward or visual image processing systems can be used for printed adaptations, for example, prints and photos. Image specialists utilize a few fundamental elements of explanation while utilizing these visual strategies. Image processing isn't just constrained to a district that should be inspected, in any case, in the analyst's information. The alliance is another essential device in image processing through visual systems. Hence, researchers apply a mix of individual information and assurance the data for image processing. The digital processing techniques help in the control of digital images by means of PC. Since the crude data from the satellite arena image sensors contain insufficiencies. To beat these deformities and get data innovativeness, it is important to try different things with various processing periods. The three general advances that must be confirmed by a wide scope of data when utilizing a digital system are the pre-processing, refreshing and data extraction.

### 3. IMAGE PROCESSING IN WIRELESS SENSOR NETWORKS

Due to the limited lifetime of the battery in each sensor, it is obvious that the reduction of the transmitted data will increase the energy efficiency and the useful life of the network. However, the most obvious solution is image compression. The purpose of image compression is to reduce the number of bits needed to represent the image, eliminating as much as possible spatial and spectral redundancies. In this research, the transmission scheme of the proposed image is based on the transformation of wavelet images. The structure of a transformation encoder is illustrated in.

Requirements: small size, high number, tether-less and low cost. The small size involves a small battery. Low cost and energy involve low power CPUs, radios with minimum bandwidth and range. The ad hoc implementation does not imply maintenance or replacement of the battery. To increase the useful life of the network, no raw data is transmitted.

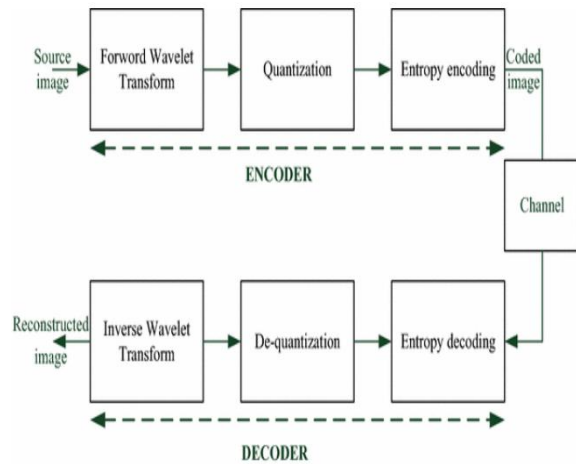

**Figure 3: Functional Block Diagram of Jpeg 2000 Encoder**

- **AD HOC Wireless Networks**

A large number of static or mobile self-classified nodes that are arbitrarily transmitted Communication with the nearest neighbour Wireless connections the connections are delicate and potentially unbalanced. The network is based on power and fades levels. The impedance is high for omnidirectional antennas. Sensor networks and sensor and actuator networks are a visible case.

- **System Model**

Consider a network of wireless multi-jump sensors that wirelessly interconnect sensor nodes prepared to recover and deal with a still image. The records, wherein the odd ones were discovered, including instances of information data, were at first spared toward the start of the calculation. In this research, no extra memory is required at any stage. For every model pixel, the low pass rot requires 8 turns (S) and 8 stage instructions (A), while the high advance requires 2 moves and 4 augmentations. The energy required for low pass/high pass rots can be described by the number of activities. The total calculation energy for this system can be prepared as the arrangement of the calculation load and the access to the data. Two degrees of wavelet rot are utilized.

#### 4. NETWORK CODING FOR WIRELESS APPLICATIONS

Network Coding (NC) is a generally ongoing subset of network information theory that has prompted incredible advancement in enhancing network performance. It includes performing activities other than simply sending and replication in the nodes that make up a network. In this research, we attempt to inspect the developments in this field and look at the effect this has had on wireless networks, as far as the improvements it has made and the resulting application to different classes inside the wireless network.

Consider the theory behind NC, the different NC schemes that have been proposed and utilized throughout the years, the development of the NC application in the physical layer of networks and a few chose NC applications in wireless networks. This section endeavors to investigate the

idea of network coding (NC), a moderately new subset of information theory, explicitly inside the space of wireless networks. Before the fundamental Section that depicts this field, the transmission of data through a network was seen basically as a progression of products, which is a trade of products without the capacity to process the products themselves.

Network coding changed this, recommending more muddled activities than essentially reproducing and transmitting data parcels could be performed on the nodes that make up a given network. This has prompted quick progress and has animated the utilization of new numerical apparatuses, in fields, for example, polynomial math, matroid theory, geometry, chart theory, combinatorial theory, and improvement, among others. Even though NC is a muddled theme to talk about without a critical numerical foundation, this research goes for a progressively casual crowd and, in this research, we will take measures to lessen the intricacy of the examined scientific theory, while simultaneously attempting to catch the different interior subtleties. In this presentation, we will likely offer a concise portrayal of what NC includes, and consequently explain the various highlights that characterize this innovation. To accomplish this, we give some information on the NC and its basic theory in this research, talk about the mainstream coding schemes right now being used in the Section and quickly investigate the network encoding dependent on the physical layer in the Section, concentrating on Network Encoding physics (PNC), as it is progressively utilized in wireless networks.

- **Theory Behind Network Coding**

The consequences of this research are communicated as the hypothesis of the most extreme cut of the base stream in the theory of the network. This hypothesis expresses that in a stream network, where information streams starting with one node then onto the next, the most extreme measure of stream from the source to the sink (greatest stream) is equivalent to the base limit that would not enable any stream to go from the source-sink when it is cut/expelled from the net with a particular goal in mind (least cut). [3] Demonstrated that when operations were permitted in moderate nodes, the most extreme multicast speed was equivalent to the base sliced from the source to every beneficiary essentially, if every one of the collectors have a similar least cut from the source, NC will enable all nodes to at the same time arrive at the base cutting limit.

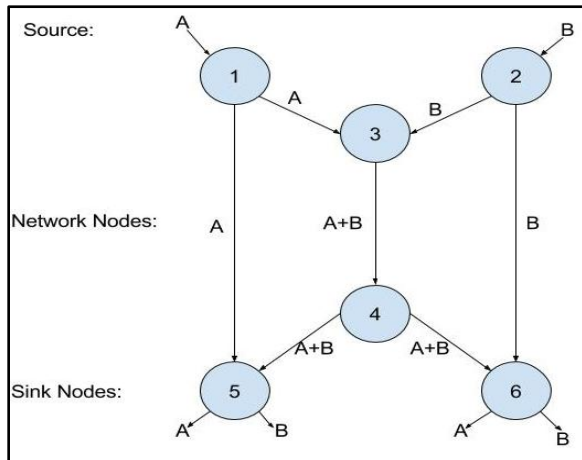

**Figure 4: Butterfly Network**

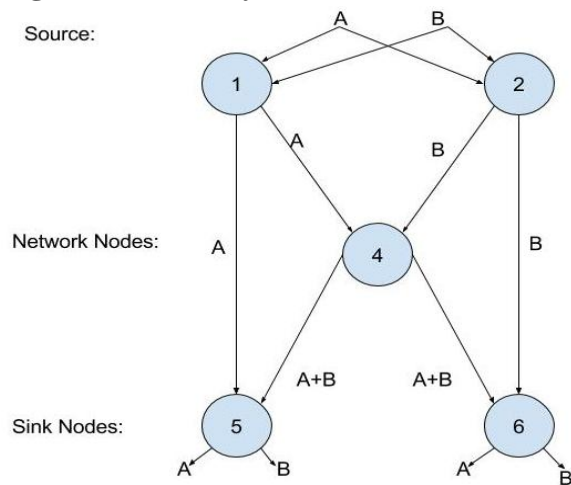

**Figure 5: Modified wireless butterfly network**

In this model, node 5 will get both A and A + B, from which it can decode B by subtracting these two qualities. Node 6 would utilize a similar technique to decode An in the wake of accepting both B and A + B. From this simple model; we can see that few other coding techniques could be connected to a variable number of bundles, in different network configurations.

The wireless network butterflies modified as shown in Figure 5 is different from the network to the original butterfly in the sense that the packet transmissions may be transmitted from the source node to more than one node. Therefore, transmissions are represented using hyper arcs, rather than arcs. We now have a brief and hopefully overview of the underlying theory and the nature of network coding.

- **Network Coding Schemes**

The way nodes code and decode the packets they transmit / receive can have a big impact on the resulting network performance. Most of the NC schemes in use today are based on algebraic theory. While the previous schemes, such as the traditional XOR coding scheme and the

deterministic linear network coding scheme were deterministic in nature, the most common schemes in use today are not deterministic, which means that they are free from the constraint of having feedback information on packages for every package sent by all receivers. In this research we will see some common coding schemes, namely Random Linear Network Coding (RLNC), Triangular Network Coding (TNC) and Opportunistic Network Coding (ONC).

- **Random Linear Network Coding**

Here, once again, we will use a network model for a general communication system consisting of sources, network nodes and sinks connected by channels that could have losses. We can represent a system of this type as a directed graph  $G = \{V, E\}$  where the vertices  $V$  represent the different nodes of the network and the set of edges  $E$  consists of arcs between the nodes and denotes the connections in the network [4]

- **Triangular Network Coding**

In order to intrinsically resolve the problem with RLNC described above, where the receivers that obtain an insufficient number of packets cannot recover the original packets, the triangular network coding has been proposed in [5]. The package coding scheme based on triangular schemes is performed in two phases. Thus, the packets are coded bit by bit, in which the bits of "0" are added in such a way as to generate a triangular model, known as triangulation, as shown in Figure 6.

$b_{1,1}$	$b_{2,1}$	$b_{3,1}$	$b_{4,1}$	...	...	$b_{B,1}$	0	0	0
0	$b_{1,2}$	$b_{2,2}$	$b_{3,2}$	$b_{4,2}$	...	...	$b_{B,2}$	0	0
0	0	$b_{1,3}$	$b_{2,3}$	$b_{3,3}$	$b_{4,3}$	...	...	$b_{B,3}$	0
0	0	0	$b_{1,4}$	$b_{2,4}$	$b_{3,4}$	$b_{4,4}$	...	...	$b_{B,4}$

Figure 6: Triangular Pattern

- **Opportunistic Network Coding**

In ONC, tracking nodes can browse all nearby transmissions and store the data packets listened to, regardless of whether they are for them or not [6]. As such, the sensor nodes know the packets listened to and routed by each neighbouring node and can perform network coding operations based on this information.

## 5. APPLICATIONS OF NC TO WIRELESS NETWORKS

It is unlikely that the incorporation of network coding in the physical layer will be practical in the near future, for a variety of reasons detailed in [7]. However, it is quite feasible to build a network coding in overlapping networks. In overlapping networks, nodes are applications that

run on computers and edges are the transport level connections between computers. Overlapping networks can be based on infrastructure, as shown by content distribution networks such as Akamai.

- **File download**

Downloading files from a server to a client computer is one of the most common tasks that occur in network communication. While the downloaded file is traditionally unicast from the server to the client, if we ignore the delay, this can also be seen as a multicast of the file from the server to a large group of clients using a proportionally large amount of buffering.

- **Video on Demand, Live Media Broadcast, and Instant Messaging (IM)**

Video on demand can be considered a specialized way to download files in which the parts of the downloaded file should arrive in order and should be decoded almost in real time, taking into account a small delay. The network encoding can be applied in this case by dividing the file into fragments, which can be downloaded sequentially. A similar technique can be used with live media streaming.

- **Wireless Mesh Networks**

In addition to an application layer overlay network, another convenient place where network encryption can be applied is a link-level network, such as a wireless mesh network. Mesh networks consist of mesh routers, which provide access to an existing infrastructure and mesh client, which provide multiple hop connectivity to mesh routers and use the connectivity provided by other client meshes.

- **Network Coding Meets Multimedia**

Although each node in the network transmits only messages in a traditional communication system, the recent network coding (NC) paradigm proposes to implement a simple network processing with combinations of packets in the nodes. NC extends the concept of "encoding" of a message beyond the encoding of the source (for compression) and encoding of the channel (for protection against errors and losses). It has been shown to increase network performance compared to the implementation of traditional networks, reduce the delay and provide robustness to transmission errors and network dynamics.

## 6. CONCLUSION

Wireless sensor networks (WSN) have drawn the attention of the research community over the most recent couple of years, driven by an abundance of hypothetical and pragmatic difficulties. This developing interest can be to a great extent credited to new applications empowered by vast scale networks of little devices equipped for collecting information from the physical environment, performing simple processing on the extricated data and transmitting it to remote locations. Critical outcomes around there over the most recent couple of years have introduced a flood of common and military applications. Starting today, most conveyed wireless sensor networks measure scalar physical wonders like temperature, pressure, stickiness, or location of items.



We examined in this research, we consider wireless sensor networks, in which very small sensors can be extended to surfaces and can collect energy from the environment, to form detection surfaces through a network of integrated communication. The sensor nodes are generally equipped with a radio transceiver, a microcontroller, a memory unit and a set of transducers with which they can acquire and process data. To reduce the size of each node and the power requirements, the transceiver oscillator is replaced by a resonant circuit on the chip. However, the central frequency of the resonant circuit is random, which means that each node chooses a random channel to transmit and another random channel to receive. Nodes can self-organize to form a multi-hop network and transmit data to a receiving node. The performance between any two nodes is constant if only routing is used, but grows linearly in the number of channels if the network coding is used and the radio frequency intervals are chosen optimally. The reason network coding is of great help here is that randomly combined packets can find their way to the destination without the need to explicitly inform the nodes where their destinations are located.

## REFERENCES

- [1]. Low-complexity and energy efficient image compression scheme for wireless sensor networks. *Computer Networks Journal*, 52(13), 2594–2603 CrossRefMATH. Lu. Q, Luo. W, Wang. J, & Chen. B 2008.
- [2]. Optimized self-organized Sensor Networks. *Sensor* 7(5), 730–742 CrossRef. Park. S, Shin. K, Abraham. A & Han. S 2007. Efficient clustering algorithms for self-organizing wireless sensor networks. *Ad Hoc Networks Journal*, 4(1), 36–59 Cross Ref. Krishnan. R & Starobinski. D 2006.
- [3]. Ahlswede, Rudolf, et al. "Network information flow." *Information Theory, IEEE Transactions on* 46.4 (2000): 1204-1216, URL: <http://www.cs.cornell.edu/courses/cs783/2007fa/researchs/acly.pdf>
- [4]. Magli, Enrico, et al. "Network coding meets multimedia: A review." *Multimedia, IEEE Transactions on* 15.5 (2013): 1195-1212, URL: <http://arxiv.org/pdf/1211.4206.pdf>
- [5]. Shen, Hang, et al. "An adaptive opportunistic network coding mechanism in wireless multimedia sensor networks." *International Journal of Distributed Sensor Networks* 2012 (2012), URL: <http://www.hindawi.com/journals/ijdsn/2012/565604/abs/>
- [6]. Liew, Soung Chang, Shengli Zhang, L. Lu, "Physical-layer network coding: Tutorial, survey, and beyond." *Physical Communication* 6 (2013): 4-42, URL: <http://arxiv.org/pdf/1105.4261.pdf>
- [7]. Feng, Chen, and Baochun Li. "1 Network Coding for Content Distribution and Multimedia Streaming in Peer-to-Peer Networks." *Network Coding: Fundamentals and Applications* (2011): 61..., URL: [https://www.researchgate.net/profile/Chen\\_Feng9/publication/267839813\\_Network\\_Coding\\_for\\_Content\\_Distribution\\_and\\_Multimedia\\_Streaming\\_in\\_Peer-to-Peer\\_Networks/links/54a163080cf256bf8baf6bb9.pdf](https://www.researchgate.net/profile/Chen_Feng9/publication/267839813_Network_Coding_for_Content_Distribution_and_Multimedia_Streaming_in_Peer-to-Peer_Networks/links/54a163080cf256bf8baf6bb9.pdf)