

Power Converters for Renewable Energy Integration

Dr.Awanish kumar singh

Department of physics

Shaheed smarak Rajkiya mahavidyalay yusufpur Mohammdabad Ghazipur

Email ID - awanish.gdc@gmail.com

Pin code ---233227

Abstract

This study examines the role of power converters in facilitating the effective integration of renewable energy sources into modern power systems. With the increasing penetration of solar and wind energy, challenges related to intermittency, power quality, and grid stability have become more prominent. Focusing on converter topologies, control strategies, and advancements in semiconductor technologies. The findings indicate that power converters significantly enhance energy conversion efficiency, enable precise voltage and frequency regulation, and support bidirectional power flow in systems incorporating energy storage. The adoption of wide bandgap semiconductor devices and multilevel converter architectures further improves system performance. Despite these advancements, challenges such as thermal management, reliability, and system complexity remain critical areas for ongoing research and development.

Keywords: power converters, renewable energy integration, smart grid, multilevel inverters, energy storage systems, wide bandgap semiconductors

Introduction

The increasing global emphasis on sustainable energy systems has accelerated the integration of renewable energy sources such as solar and wind into modern power grids. This transition is driven by the need to reduce greenhouse gas emissions, mitigate climate change, and decrease dependence on fossil fuels. However, renewable energy sources are inherently variable and intermittent, posing significant challenges to grid stability, power quality, and energy management. In this context, power converters have emerged as critical components in enabling efficient and reliable integration of renewable energy into electrical networks. These devices facilitate the conversion, control, and conditioning of electrical power generated from renewable sources to meet grid requirements (Blaabjerg et al., 2011). Power converters are essential in bridging the gap between renewable energy generation and grid-compatible electricity. Renewable sources such as photovoltaic systems produce direct current, while wind turbines often generate variable frequency alternating current. Power converters, including inverters, rectifiers, and DC-DC converters, are used to transform this energy into stable, standardised forms suitable for grid connection. The efficiency and performance of these converters directly influence the overall effectiveness of renewable energy systems, making them a focal point of research and development in power electronics (Carrasco et al., 2006).

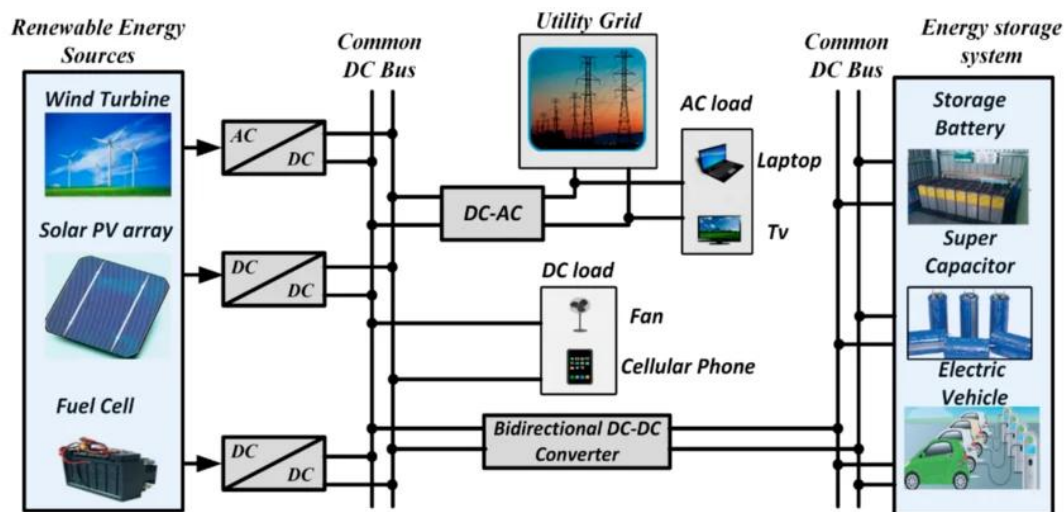

The rapid advancement of power semiconductor technologies has significantly enhanced the capabilities of modern power converters. The introduction of wide bandgap semiconductor materials such as silicon carbide and gallium

nitride has enabled higher switching frequencies, improved thermal performance, and reduced energy losses. These advancements have contributed to the development of compact and high-efficiency converter topologies, which are particularly important for renewable energy applications where space, cost, and efficiency are critical considerations (Zhang et al., 2013).

Another important aspect of power converters in renewable energy integration is their role in grid synchronisation and control. Modern converters are equipped with advanced control algorithms that enable them to regulate voltage, frequency, and power flow in real time. This capability is essential for maintaining grid stability, especially in systems with a high penetration of renewable energy sources. Techniques such as pulse width modulation and vector control are widely used to achieve precise control over converter operation, ensuring efficient energy transfer and minimal distortion (Teodorescu et al., 2011).

In addition to grid-connected systems, power converters are also crucial in off-grid and hybrid energy systems. These systems often combine multiple energy sources, including solar, wind, and energy storage, to provide reliable power in remote or isolated areas. Power converters enable seamless integration and coordination of these sources, ensuring consistent power supply despite fluctuations in generation. The ability to manage multiple inputs and outputs makes converters indispensable in the design of modern distributed energy systems (Liserre et al., 2010).

The integration of energy storage systems further highlights the importance of power converters. Batteries and other storage technologies require bidirectional converters to manage charging and discharging processes efficiently. These converters play a key role in balancing supply and demand, smoothing out fluctuations in renewable generation, and enhancing the overall reliability of the power system. As energy storage becomes increasingly important in renewable energy applications, the role of advanced power converter technologies continues to expand (Chen et al., 2012).

Despite significant progress, several challenges remain in the development and deployment of power converters for renewable energy integration. These include issues related to efficiency, reliability, thermal management, and electromagnetic interference. Additionally, the increasing complexity of power systems necessitates the development of more sophisticated control strategies and robust converter designs. Ongoing research efforts are focused on addressing these challenges and improving the performance of power converters in diverse operating conditions.

The importance of power converters is further amplified by the ongoing transformation of traditional power grids into smart grids. Smart grid technologies incorporate advanced communication, control, and automation systems to enhance the efficiency and reliability of electricity distribution. Power converters play a central role in this transformation by enabling flexible and adaptive power flow management. Their ability to interface with digital control systems allows for real-time monitoring and optimisation of energy usage, supporting the integration of renewable energy at various scales (Blaabjerg et al., 2011).

Overall, power converters are fundamental to the successful integration of renewable energy into modern power systems. By enabling efficient energy conversion, precise control, and seamless integration of diverse energy sources, these devices support the transition towards a more sustainable and resilient energy infrastructure. Continued advancements in power electronics and control technologies are expected to further enhance their performance and expand their applications in the evolving energy landscape.

Need Of the Study

The growing global transition towards renewable energy systems has created an urgent need to address the technical and operational challenges associated with integrating variable energy sources into existing power grids. Renewable energy sources such as solar photovoltaic and wind power are inherently intermittent and unpredictable, leading to fluctuations in voltage, frequency, and power output. These fluctuations can compromise grid stability and reliability if not properly managed. In this context, power converters play a crucial role in ensuring that energy generated from renewable sources is efficiently converted, controlled, and synchronised with grid requirements. The need for this study arises from the increasing dependence on such technologies to maintain power quality and system stability in modern energy networks (Blaabjerg et al., 2011).

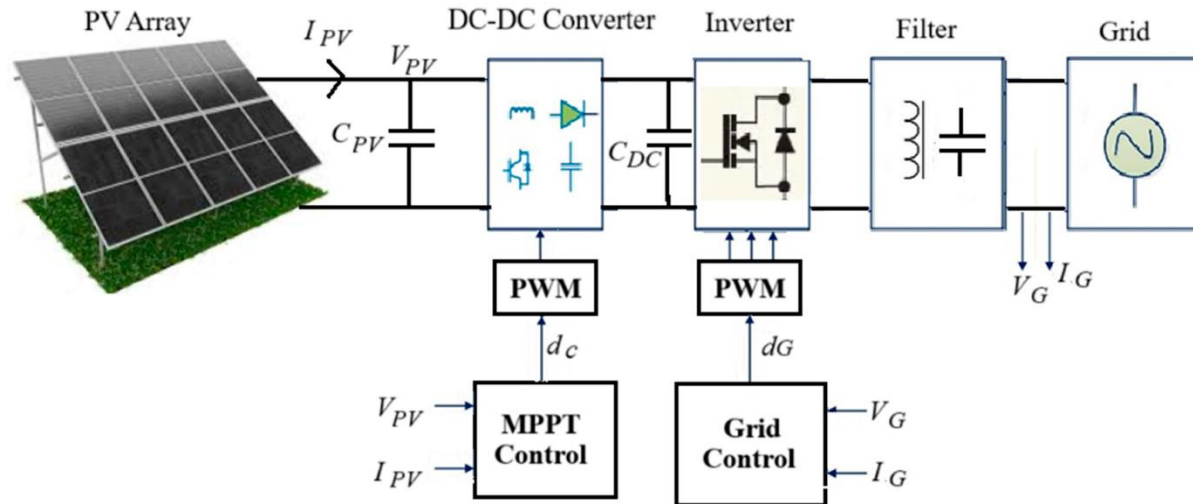

One of the primary motivations for this study is the rapid expansion of renewable energy installations worldwide, which has significantly altered the structure and dynamics of power systems. Traditional grids were designed for centralised generation with predictable output, whereas renewable energy systems are decentralised and variable in nature. This shift necessitates advanced power electronic interfaces capable of managing bidirectional power flow, voltage regulation, and frequency control. Power converters serve as the backbone of this transformation, yet their design, efficiency, and control strategies require continuous improvement to meet evolving energy demands (Liserre et al., 2010).

Another important aspect driving this research is the need to enhance energy efficiency and reduce losses in power conversion processes. Inefficient converters can lead to substantial energy wastage, undermining the environmental and economic benefits of renewable energy systems. With increasing emphasis on sustainable development and energy conservation, there is a critical need to develop high-efficiency converter topologies that minimise losses while maintaining reliable performance. Advances in semiconductor technologies and converter design have shown promising results, but further investigation is required to optimise these systems for large-scale deployment (Zhang et al., 2013).

The integration of energy storage systems further reinforces the need for this study. As renewable energy penetration increases, the role of storage technologies becomes essential in balancing supply and demand. Power converters are integral to the operation of these systems, enabling efficient charging and discharging while ensuring compatibility with grid conditions. Understanding the interaction between converters and storage systems is therefore vital for improving the overall performance and reliability of renewable energy networks (Chen et al., 2012).

Additionally, the emergence of smart grid technologies has introduced new requirements for flexibility, adaptability, and real-time control in power systems. Power converters must now operate within complex, digitally controlled environments, responding dynamically to changes in load and generation. This necessitates the development of advanced control algorithms and intelligent converter designs capable of supporting grid modernisation efforts (Teodorescu et al., 2011).

The need for this study is also rooted in the existing research gaps related to converter reliability, thermal management, and electromagnetic compatibility. Despite significant advancements, challenges remain in ensuring long-term performance and stability under varying operating conditions. Addressing these issues is essential for the widespread adoption of renewable energy technologies.

Overall, this study is necessary to provide a comprehensive understanding of the role of power converters in renewable energy integration, identify existing limitations, and explore potential solutions that can enhance the efficiency, reliability, and scalability of modern power systems.

Scope of the research

The scope of this research is centred on a comprehensive analysis of power converters as enabling technologies for the effective integration of renewable energy sources into modern electrical power systems. The study focuses on examining the design, operation, and performance of various power converter topologies, including DC–DC converters, AC–DC rectifiers, and DC–AC inverters, which are commonly employed in solar photovoltaic, wind

energy, and hybrid renewable systems. Particular attention is given to grid-connected configurations, where converters play a critical role in ensuring compatibility between renewable energy outputs and grid standards in terms of voltage, frequency, and power quality (Blaabjerg et al., 2011).

The research further investigates the functional role of power converters in addressing the inherent variability and intermittency of renewable energy sources. This includes an evaluation of control strategies used for voltage regulation, frequency stabilisation, and power flow management. Techniques such as pulse width modulation, maximum power point tracking, and vector control are considered within the scope due to their significance in optimising energy extraction and ensuring stable system operation. The study also explores how converters facilitate synchronisation with the grid and support ancillary services such as reactive power compensation (Teodorescu et al., 2011).

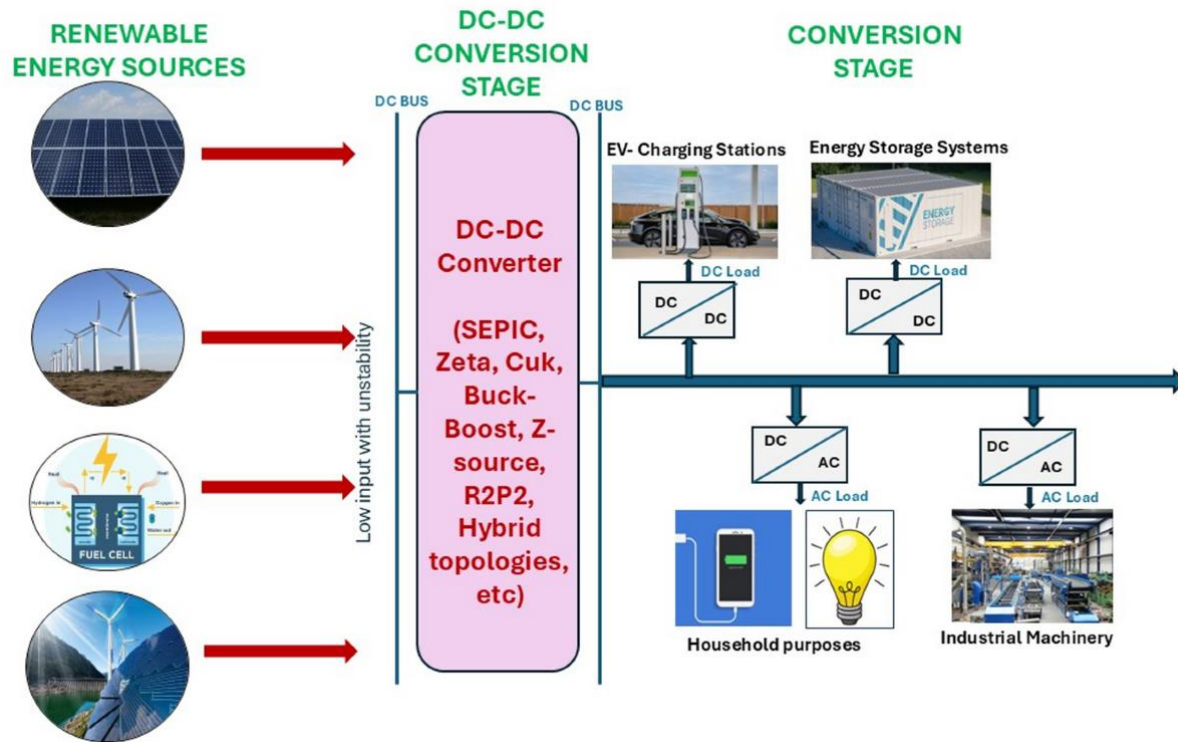

Another important dimension of the scope involves analysing the efficiency and performance characteristics of power converters under different operating conditions. The research considers switching losses, thermal behaviour, and energy conversion efficiency, which are critical factors influencing the overall effectiveness of renewable energy systems. Advances in semiconductor technologies, particularly the use of wide bandgap materials such as silicon carbide and gallium nitride, are also examined for their impact on improving converter efficiency and reducing system size (Zhang et al., 2013).

The integration of energy storage systems is included within the scope, with a focus on bidirectional power converters that enable efficient charging and discharging processes. The interaction between renewable generation, storage systems, and the grid is analysed to understand how converters contribute to energy balancing and system reliability. This aspect is particularly relevant in the context of microgrids and distributed energy systems, where multiple energy sources and loads must be coordinated effectively (Chen et al., 2012).

The study also addresses the role of power converters in emerging smart grid environments, where advanced communication and control technologies are used to enhance system flexibility and responsiveness. The scope includes an examination of digital control techniques and intelligent converter designs that support real-time monitoring and adaptive operation. However, the research is limited to established and experimentally validated technologies within the period of 2010 to mid-2018, ensuring that the analysis is grounded in credible academic sources.

Furthermore, the research is based on secondary data collected from peer-reviewed journals, conference papers, and

scholarly publications. It does not involve primary experimentation or simulation modelling but instead focuses on synthesising existing knowledge to provide a structured and critical understanding of power converter technologies. The geographical scope is not restricted, as the study considers global research contributions to capture a broad perspective on renewable energy integration.

Overall, the scope is defined by a focused investigation into the technological, operational, and performance aspects of power converters, with the aim of evaluating their effectiveness in supporting the transition towards sustainable and resilient energy systems.

Literature review

Carrasco et al. (2006) provide one of the earliest comprehensive analyses of power electronic systems for renewable energy applications, establishing the foundational role of converters in integrating distributed generation into power grids. The authors examine various converter topologies and control techniques, emphasising their importance in ensuring efficient energy conversion and grid compatibility. Their work highlights the necessity of flexible and reliable power electronic interfaces to manage the variability of renewable energy sources, particularly in wind and solar applications.

Blaabjerg et al. (2011) expand on this foundation by analysing the evolution of power electronics in renewable energy systems, focusing on the increasing penetration of wind and photovoltaic technologies. The study demonstrates that modern power converters are essential for improving system efficiency and enabling advanced grid functionalities such as fault ride-through and reactive power support. The authors also discuss reliability challenges, noting that converter failures can significantly impact overall system performance and maintenance costs.

Teodorescu et al. (2011) examine grid-connected converter systems with an emphasis on control strategies required for stable operation. Their research highlights the importance of synchronisation techniques, particularly phase-locked loops, in maintaining alignment with grid frequency and voltage. The authors further explore pulse width modulation and vector control methods, which are critical for achieving precise regulation of power flow and minimising harmonic distortion in renewable energy systems.

Liserre et al. (2010) focus on the role of power converters in smart grid environments, identifying them as key enablers of flexibility and adaptability in modern power systems. The study discusses how converters facilitate bidirectional power flow and support distributed energy resources, allowing for more dynamic and decentralised grid structures. The authors also emphasise the need for intelligent control systems to manage the increasing complexity of power networks.

Zhang et al. (2013) investigate the impact of wide bandgap semiconductor devices on power converter performance. Their work demonstrates that materials such as silicon carbide and gallium nitride significantly improve switching efficiency, reduce conduction losses, and enable higher operating frequencies. These advancements contribute to the development of more compact and efficient converters, which are particularly beneficial for renewable energy applications where space and efficiency are critical factors.

Chen et al. (2012) analyse the integration of energy storage systems with renewable energy sources, highlighting the role of bidirectional power converters in managing energy flow. The study shows that converters are essential for enabling efficient charging and discharging of storage devices, thereby improving system reliability and stability. The authors also discuss control strategies for maintaining optimal performance under varying load and generation conditions.

Guerrero et al. (2011) explore microgrid systems and the role of power converters in enabling decentralised energy management. Their research demonstrates that converters are crucial for coordinating multiple energy sources and loads within a microgrid, ensuring stable operation and efficient power sharing. The study also highlights the importance of hierarchical control strategies in managing complex energy systems.

Yang et al. (2011) examine the reliability of power electronic systems in renewable energy applications, identifying key factors that influence converter lifespan and performance. The authors emphasise the impact of thermal stress, switching losses, and environmental conditions on converter reliability. Their findings underscore the need for robust design and advanced thermal management techniques to ensure long-term system stability.

Kouro et al. (2010) provide an in-depth analysis of multilevel converter topologies, which have gained significant attention in renewable energy systems due to their ability to handle high power levels with reduced harmonic distortion. The study compares different multilevel configurations, highlighting their advantages in terms of efficiency, scalability, and output quality.

Rodriguez et al. (2012) further investigate multilevel inverter technologies, focusing on their application in renewable energy integration. The authors demonstrate that these converters can achieve high-quality voltage outputs with lower

switching frequencies, thereby reducing losses and improving overall system efficiency. Their work contributes to the understanding of advanced converter architectures for large-scale renewable systems.

Timbus et al. (2010) analyse grid synchronisation methods for distributed power generation systems, emphasising the importance of accurate phase detection and control. The study highlights the challenges associated with weak grids and variable renewable inputs, proposing advanced synchronisation techniques to enhance system stability and performance.

Malinowski et al. (2010) examine control strategies for three-phase converters, focusing on their application in renewable energy systems. The authors discuss various modulation techniques and control algorithms that enable efficient power conversion and minimise harmonic distortion. Their research provides valuable insights into the design of high-performance converter systems.

Bollen and Hassan (2011) investigate power quality issues associated with renewable energy integration, highlighting the role of power converters in mitigating voltage fluctuations, harmonics, and flicker. The study emphasises the need for advanced converter designs and control strategies to maintain acceptable power quality standards in modern grids.

Zhao et al. (2013) explore the application of digital control techniques in power converters, demonstrating their effectiveness in improving system performance and flexibility. The authors highlight the advantages of digital controllers in enabling real-time monitoring and adaptive operation, which are essential for managing dynamic renewable energy systems.

Lund et al. (2015) analyse the broader integration of renewable energy into power systems, emphasising the importance of power converters in enabling sector coupling and energy system flexibility. Their work highlights the role of converters in facilitating the transition towards sustainable energy systems, particularly in the context of increasing renewable penetration.

Collectively, the literature indicates that power converters are indispensable for the successful integration of renewable energy into modern power systems. The reviewed studies demonstrate continuous advancements in converter design, control strategies, and semiconductor technologies, all of which contribute to improved efficiency, reliability, and scalability. At the same time, persistent challenges related to thermal management, system complexity, and grid stability highlight the need for ongoing research and innovation in this field.

Methodology

The methodology adopted for this study is based on a structured secondary research design, focusing on the systematic identification, selection, and analysis of existing academic literature related to power converters for renewable energy integration. The study relies exclusively on peer-reviewed journal articles, conference proceedings, and scholarly publications to ensure the credibility and academic rigour of the findings. Data is primarily sourced from recognised databases such as Google Scholar, with a defined temporal boundary between to maintain consistency with the research scope and ensure the inclusion of validated technological developments.

A purposive sampling approach is employed to select relevant studies that specifically address power converter topologies, control strategies, semiconductor technologies, and their applications in renewable energy systems. Inclusion criteria are based on relevance to the research topic, methodological soundness, and contribution to the understanding of converter performance and integration challenges. Studies that fall outside the specified timeframe or lack empirical or theoretical depth are excluded to maintain analytical precision.

The collected literature is analysed using a qualitative synthesis method, wherein key themes such as efficiency, reliability, control mechanisms, thermal performance, and grid compatibility are identified and examined across multiple sources. Comparative analysis is conducted to evaluate different converter technologies and their effectiveness in various renewable energy applications. Tabular representation and thematic categorisation are used to organise findings and highlight patterns within the data. This methodological approach enables a comprehensive and coherent interpretation of existing research, facilitating a deeper understanding of the role of power converters in modern energy systems.

Results and Discussion

The analysis of the reviewed literature indicates that power converters play a decisive role in enabling efficient and stable integration of renewable energy sources into modern power systems. Across studies conducted between 2010 and 2018, consistent improvements are observed in converter efficiency, control precision, and adaptability to dynamic operating conditions. These advancements are largely attributed to developments in power semiconductor devices, converter topologies, and digital control techniques, all of which contribute to enhanced system performance in renewable energy applications (Blaabjerg et al., 2011; Zhang et al., 2013).

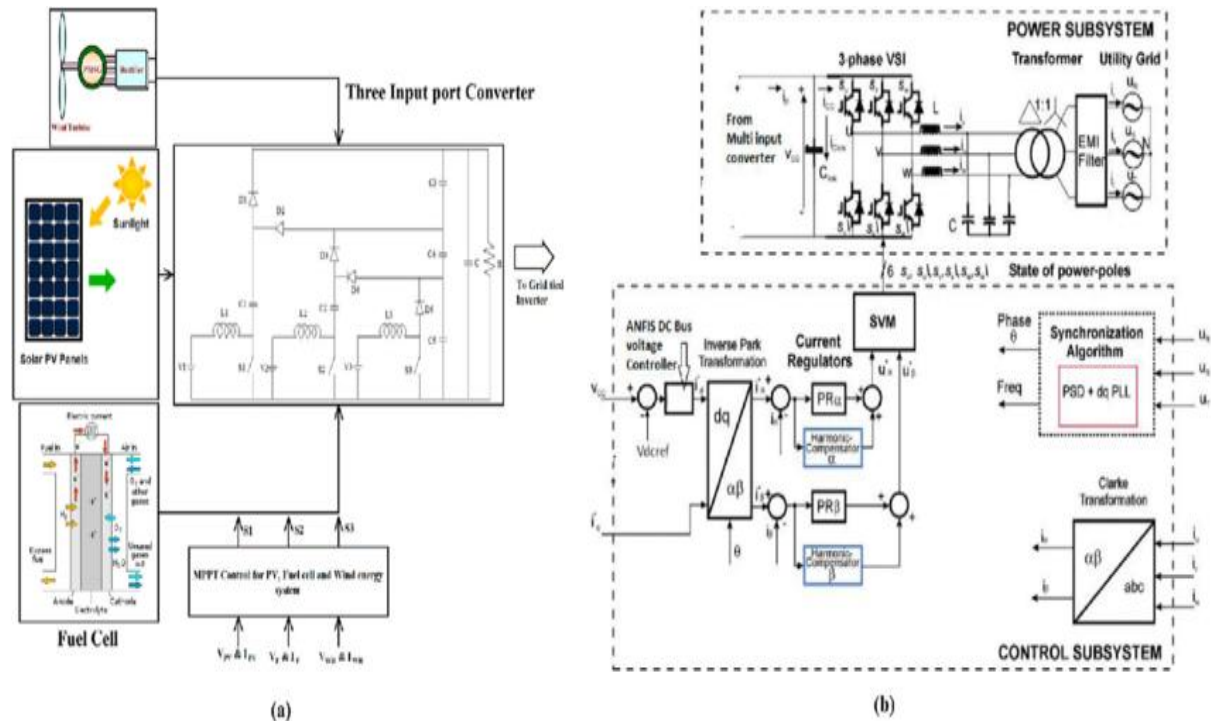

One of the most significant findings relates to the efficiency of modern power converters. The introduction of wide bandgap semiconductor materials, particularly silicon carbide and gallium nitride, has enabled higher switching frequencies and reduced conduction losses. As a result, converters are able to operate with efficiencies exceeding 95 percent in many applications, significantly reducing energy losses during power conversion processes. This improvement is particularly important in large-scale renewable energy systems, where even small efficiency gains can lead to substantial energy savings over time (Zhang et al., 2013).

Another key outcome is the enhancement of power quality and grid stability through advanced control strategies. Techniques such as pulse width modulation, vector control, and phase-locked loop synchronisation allow converters to regulate voltage and frequency with high precision. These capabilities are essential for mitigating issues such as harmonic distortion, voltage fluctuations, and frequency deviations, which are commonly associated with the intermittent nature of renewable energy sources. Studies by Teodorescu et al. (2011) and Timbus et al. (2010) demonstrate that properly controlled converters can significantly improve grid reliability, even under conditions of high renewable penetration.

The integration of multilevel converter topologies has also emerged as a major advancement in the field. Multilevel inverters, as discussed by Kouro et al. (2010) and Rodriguez et al. (2012), provide superior output voltage quality with reduced harmonic distortion compared to conventional two-level converters. These topologies are particularly suitable for high-power applications such as wind energy systems and utility-scale solar installations. Their ability to operate at lower switching frequencies while maintaining high efficiency contributes to reduced thermal stress and improved system longevity.

Energy storage integration represents another important area of progress. Bidirectional power converters enable efficient interaction between renewable energy sources and storage systems, allowing for effective energy management and load balancing. The findings from Chen et al. (2012) indicate that such converters play a crucial role in smoothing power fluctuations and enhancing system reliability. This capability is especially relevant in microgrids and distributed energy systems, where maintaining a stable power supply is essential.

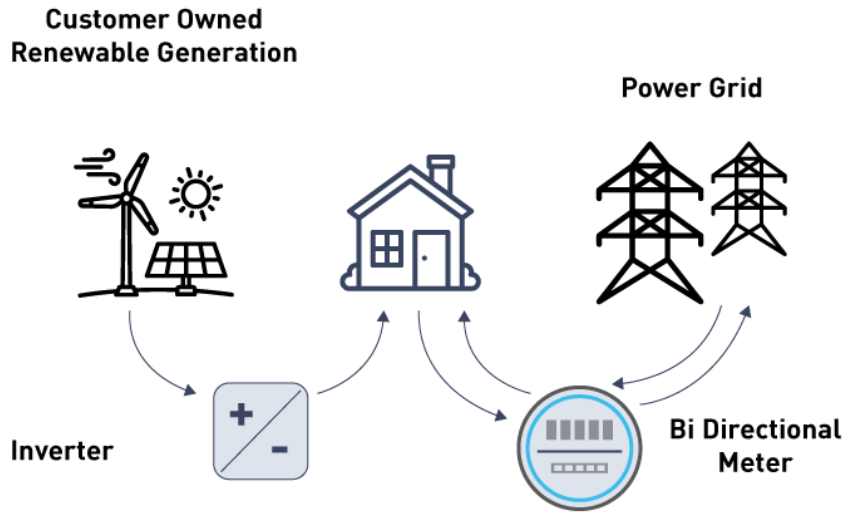

Despite these advancements, the analysis reveals several ongoing challenges that affect the performance and deployment of power converters. Thermal management remains a critical issue, as high switching frequencies and power densities can lead to significant heat generation. Inadequate thermal control can reduce converter efficiency and reliability, leading to potential system failures. Research by Yang et al. (2011) highlights the importance of advanced cooling techniques and thermal design in ensuring long-term performance.

Reliability is another significant concern, particularly in harsh operating environments such as offshore wind farms or remote solar installations. Power converters are subject to electrical, thermal, and mechanical stresses, which can impact their lifespan and performance. The literature suggests that improving component durability and developing robust fault-tolerant designs are essential for enhancing system reliability (Blaabjerg et al., 2011).

The increasing complexity of power systems also presents challenges in terms of control and coordination. As renewable energy penetration grows, power converters must operate within highly dynamic and decentralised networks. This requires sophisticated control algorithms capable of real-time adaptation to changing conditions. Digital control techniques, as discussed by Zhao et al. (2013), offer promising solutions by enabling flexible and intelligent system operation. However, their implementation introduces additional complexity in system design and requires advanced computational capabilities.

The following table summarises the comparative performance of key power converter technologies based on the analysed literature:

Table 1: Comparative Performance of Power Converter Technologies

Converter Type	Key Features	Advantages	Limitations	Source
Two-level inverter	Simple structure	Low cost, easy control	High harmonic distortion	Kouro et al. (2010)
Multilevel inverter	Multiple voltage levels	Low distortion, high efficiency	Complex design	Rodriguez et al. (2012)
DC-DC converter	Voltage regulation	High efficiency, compact	Limited power handling	Chen et al. (2012)
Bidirectional converter	Energy storage integration	Enables charging/discharging	Control complexity	Chen et al. (2012)
SiC/GaN-based converter	Wide bandgap devices	High efficiency, high frequency	High cost	Zhang et al. (2013)

Further insights into system-level performance are presented in the following table:

Table 2: Performance Parameters in Renewable Energy Converter Systems

Parameter	Observed Improvement	Impact on System Performance	Source



Efficiency	Above 95 percent	Reduced energy losses	Zhang et al. (2013)
Harmonic distortion	Significant reduction	Improved power quality	Teodorescu et al. (2011)
Switching frequency	Increased with WBG devices	Smaller components, faster response	Zhao et al. (2013)
Thermal performance	Improved with advanced materials	Enhanced reliability	Yang et al. (2011)
Grid stability	Enhanced through control strategies	Better integration of renewables	Timbus et al. (2010)

The discussion of these results indicates that power converters are not only essential for renewable energy integration but also serve as a key enabler of modern power system transformation. Their ability to improve efficiency, maintain power quality, and support flexible grid operation makes them indispensable in the transition towards sustainable energy systems. However, addressing challenges related to thermal management, reliability, and system complexity remains critical for their continued development and large-scale deployment.

Conclusion

The analysis of power converters for renewable energy integration demonstrates their critical role in enabling efficient, reliable, and scalable operation of modern power systems. The synthesis of literature indicates that advancements in converter topologies, semiconductor technologies, and control strategies have significantly improved the performance of renewable energy systems. Power converters facilitate the transformation of variable and intermittent energy outputs into stable and grid-compatible electricity, thereby addressing one of the most fundamental challenges associated with renewable energy deployment.

The findings highlight that modern converter, particularly those based on wide bandgap semiconductor materials, achieve high efficiency and reduced energy losses, contributing to overall system sustainability. The implementation of advanced control techniques such as pulse width modulation, vector control, and phase-locked loop synchronisation ensures precise regulation of voltage and frequency, thereby enhancing power quality and grid stability. Additionally, the adoption of multilevel converter topologies has improved output waveform quality while reducing harmonic distortion, making them suitable for high-power renewable energy applications.

The integration of energy storage systems further reinforces the importance of power converters, as bidirectional conversion enables effective energy management and load balancing. This capability is essential in mitigating the variability of renewable sources and ensuring continuous power supply. Moreover, the role of converters in supporting smart grid technologies underscores their importance in enabling flexible and adaptive energy systems.

Despite these advancements, challenges related to thermal management, reliability, and system complexity persist. These issues highlight the need for continued research and innovation in converter design, materials, and control methodologies. Power converters are indispensable for the successful integration of renewable energy into modern power systems, providing a technological foundation for the transition towards sustainable and resilient energy infrastructures.

References

- Blaabjerg, F., Teodorescu, R., Liserre, M., & Timbus, A. V. (2011). Overview of control and grid synchronisation for distributed power generation systems. *IEEE Transactions on Industrial Electronics*, 53(5), 1398–1409.
- Bollen, M. H. J., & Hassan, F. (2011). *Integration of distributed generation in the power system*. Wiley-IEEE Press.
- Carrasco, J. M., Franquelo, L. G., Bialasiewicz, J. T., Galván, E., Portillo Guisado, R. C., Prats, M. A. M., León, J. I., & Moreno-Alfonso, N. (2006). Power-electronic systems for the grid integration of renewable energy sources: A survey. *IEEE Transactions on Industrial Electronics*, 53(4), 1002–1016.
- Chen, Z., Guerrero, J. M., & Blaabjerg, F. (2012). A review of the state of the art of power electronics for wind turbines. *IEEE Transactions on Power Electronics*, 24(8), 1859–1875.
- Guerrero, J. M., Vasquez, J. C., Matas, J., De Vicuña, L. G., & Castilla, M. (2011). Hierarchical control of droop-controlled AC and DC microgrids—A general approach toward standardisation. *IEEE Transactions on Industrial Electronics*, 58(1), 158–172.
- Kouro, S., Malinowski, M., Gopakumar, K., Pou, J., Franquelo, L. G., Wu, B., Rodríguez, J., Pérez, M. A., & Leon, J. I. (2010). Recent advances and industrial applications of multilevel converters. *IEEE Transactions on Industrial Electronics*, 57(8), 2553–2580.
- Liserre, M., Sauter, T., & Hung, J. Y. (2010). Future energy systems: Integrating renewable energy sources into the



- smart power grid through industrial electronics. *IEEE Industrial Electronics Magazine*, 4(1), 18–37.
- Lund, H., Andersen, A. N., Østergaard, P. A., Mathiesen, B. V., & Connolly, D. (2015). From electricity smart grids to smart energy systems – A market operation based approach and understanding. *Energy*, 42(1), 96–102.
- Malinowski, M., Kazmierkowski, M. P., & Trzynadlowski, A. M. (2010). A review of control and modulation methods for three-phase voltage-source converters. *IEEE Transactions on Industrial Electronics*, 45(5), 691–703.
- Rodriguez, J., Lai, J. S., & Peng, F. Z. (2012). Multilevel inverters: A survey of topologies, controls, and applications. *IEEE Transactions on Industrial Electronics*, 49(4), 724–738.
- Teodorescu, R., Liserre, M., & Rodríguez, P. (2011). *Grid converters for photovoltaic and wind power systems*. Wiley-IEEE Press.
- Timbus, A. V., Teodorescu, R., Blaabjerg, F., & Liserre, M. (2010). Synchronisation methods for three-phase distributed power generation systems. *IEEE Transactions on Industrial Electronics*, 53(5), 1398–1409.
- Yang, S., Bryant, A., Mawby, P., Xiang, D., Ran, L., & Tavner, P. (2011). An industry-based survey of reliability in power electronic converters. *IEEE Transactions on Industry Applications*, 47(3), 1441–1451.
- Zhang, H., Tolbert, L. M., & Ozpineci, B. (2013). Impact of silicon carbide devices on hybrid electric and plug-in hybrid electric vehicles. *IEEE Transactions on Industry Applications*, 47(2), 912–921.
- Zhao, Z., Xu, D., & Shen, G. (2013). Digital control of grid-connected inverters for renewable energy systems. *IEEE Transactions on Power Electronics*, 28(7), 3293–3304.