

## High-Voltage Switch Using Series-Connected IGBTs With Simple Auxiliary Circuit

**\*Gaurav Trivedi**

### **ABSTRACT**

For high-voltage applications, the series operation of devices is necessary to handle high voltage with limited voltage rating devices. In the case of self turn-off devices, however, the series operation of devices is very difficult. The main problem associated with series-connected devices is how to guarantee the voltage balance among the devices both at the static and the dynamic transient states. This paper presents a simple and reliable voltage-balancing circuit for the series operation of devices to overcome the disadvantages of solutions presented so far, such as complex control or circuit, low reliability, and limited number of devices to be connected. The proposed balancing circuit realizes a complete Voltage balancing at both static and dynamic states and allows series operation of an almost unlimited number of devices. The operation principle and analysis are presented and tested on 16 series connected insulated gate bipolar transistors to handle 20-kV/400-A switching.

---

\*Professor, GGNIT, Greater Noida

## INTRODUCTION

POWER semiconductor device technology has been continually developed far to get higher voltage/current ratings, lower conduction/switching losses, and easier drive. As a result, the performance of devices has been much improved and new devices such as insulated gate bipolar transistors (IGBTs), integrated gate commutated thyristors (IGCTs), etc. have been presented. Among various power devices, the IGBT is becoming the best candidate from low- to high-power applications because it has advantages which include high voltage/current rating, fast switching, and easy drive capabilities. The recently presented IGBT has a 6.5-kV/3-kA rating. In recent years, the demand for high-voltage conversion applications, such as high-voltage inverters, high-voltage pulse generators, high-voltage dc transmission systems (HVDC), flexible ac transmission systems (FACTS), etc., have been increased. Since the voltage rating of these applications usually ranges several tens of kilovolts, the power processing cannot be accomplished with any single device. To do this, several devices should be connected in series and operated simultaneously. For the self turn-off device, however, the series operation of devices is very difficult because of tolerances in device characteristic and/or the mismatching of the driving circuit. Recently, the series operation technique for power semiconductor devices, especially IGBTs, has been introduced and discussed in [1]–[4]. One of the most important aspects in series operation of devices is to equalize the static and dynamic balancing of the voltage. The static voltage balancing can be simply achieved by connecting small balancing resistors in parallel with each device. The dynamic voltage balancing during the switching transient is much more difficult to achieve. Two dynamic voltage-balancing techniques are available: load-side balancing and gate— side balancing. The load-side balancing employs a snubber circuit and/or a clamp circuit. The snubber circuit and/or clamp circuit provide dynamic voltage balancing by limiting the device voltage rising rate  $dv/dt$  and/or clamping the peak voltage. This technique, however, cannot be used for high-power applications since much loss is involved in the snubber and clamp circuits which is proportional to the switching frequency. To solve this problem, an active gate control technique has been presented in the last few years, which does not degrade switching transient characteristic

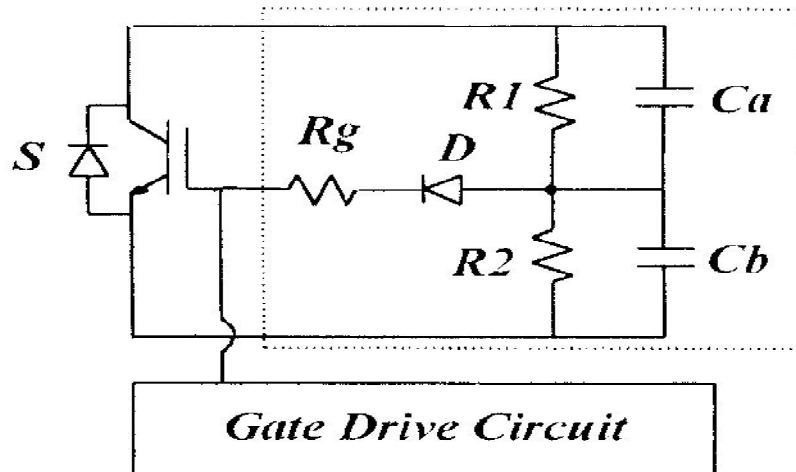

Fig.1:Proposed auxiliary circuit for series operation of devices (inside dashed line )

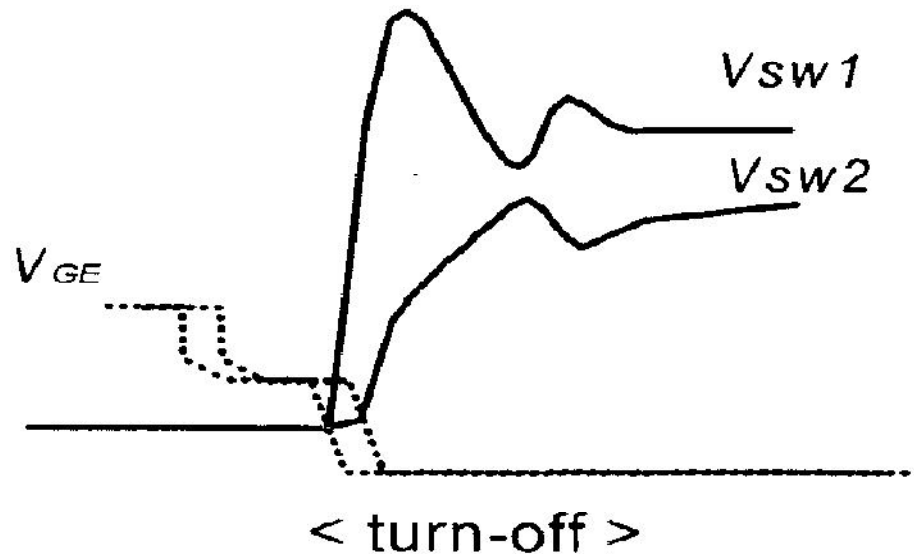
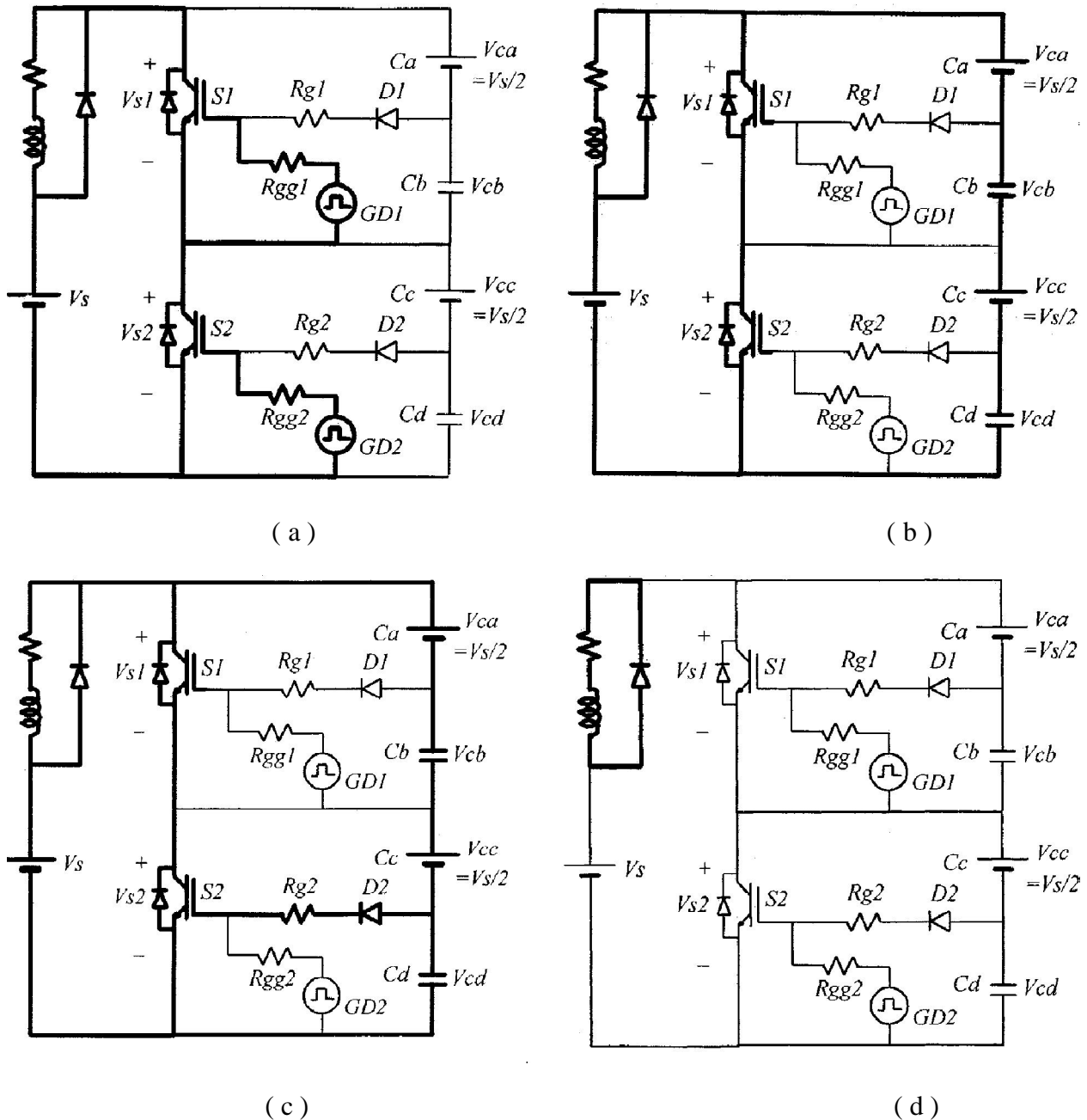

Fig. 2. Typical voltage waveforms of IGBTs during a switching transient

Each gate drive circuit should be actively controlled so that all device voltages are increased or decreased at the same rate. To do this, each voltage of the devices has to be sensed and fed back to the active gate control circuit, resulting in a complex drive circuit, low reliability, and increased switching loss [6]. Therefore, this technique may not be an economical and practical solution. In this paper, a new simple voltage-balancing circuit is presented for both the static and dynamic voltage balancing as shown in Fig. 1. This circuit, which consists of two small capacitors, three small resistors, and one small diode, is attached to each device and provides an

active gate control effect. Additional snubber circuits or a special complex gate drive are not required. In addition, the proposed scheme gives a minor effect on the switching time so that it has much lower switching loss compared to the conventional active gate control technique. Therefore, the proposed technique is simple, low in cost, with high reliability and an unlimited number of devices to be connected in series.



The operation principle and analysis are presented and tested on 16 series-connected IGBTs to handle 20-kV/400-A switching. The experimental results with and without the proposed auxiliary circuit are compared.

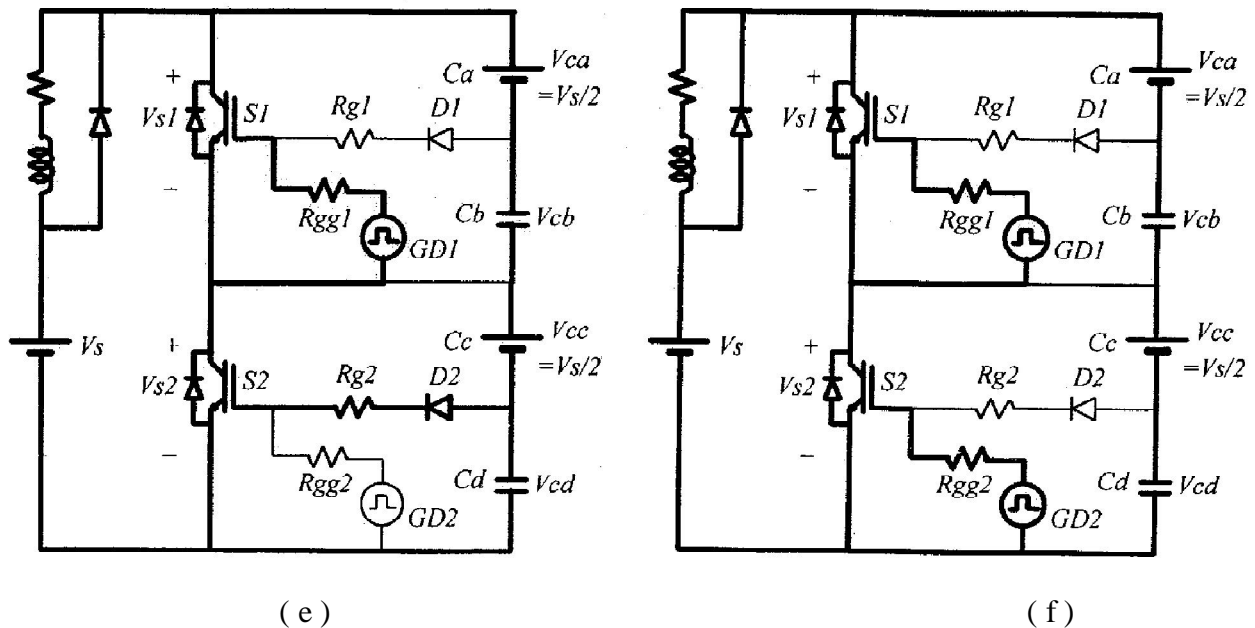

Fig. 3. Operational modes. (a) Mode 1. (b) Mode 2. (c) Mode 3. (d) Mode 4. (e) Mode 5. (f) Mode 6.

## II. SERIES OPERATION OF DEVICES:

The series operation of self turn-off devices is not easy because of the following reasons:

- unequal device switching characteristics;
- unequal device leakage current;
- unequal stray inductance in the series circuit;
- unequal gate drive delay.

Fig. 2 shows the typical waveforms of two series-connected IGBTs. After the gate signal goes off, the device voltages are increased in different  $dv/dt$  rates and reach unbalanced peak and steady state value. The difference of  $dv/dt$  and the peak mainly depend on the difference of device switching characteristics, stray inductance, and gate drive delay time, while the difference

of steady-state voltage depends on the difference of the leakage current and the output capacitance of each device. If the peak voltage of one device goes higher than the device rating, that device will be broken and the overall system will fail. Therefore, the voltage-balancing technique is necessary to balance the device voltage, even when all bad conditions are encountered.

A simple resistive voltage-dividing circuit guarantees the voltage balance of devices in the static conditions. The dynamic balancing of devices, however, is much more difficult to achieve. Using a snubber circuit for dynamic voltage balancing is not practical, since much loss should be involved. The active gate control technique achieves dynamic voltage by device voltage feedback. This, however, has a reliability problem and additional switching loss. The proposed technique achieves dynamic voltage balance with a simple auxiliary circuit, which is a simple, low-cost, and reliable technique.

### III. OPERATION PRINCIPLE:

The proposed voltage-sharing circuit consists of two capacitors, three resistors, and one diode, and all these components have a very small rating compared to those of the main switching devices.  $R_1$ ,  $R_2$  are voltage-sharing resistors, obviously for static voltage balancing. The other components are for the dynamic voltage balancing. The operation of the static voltage balancing is obvious and, thus, omitted here. The operational mode diagrams and waveforms of the proposed circuit are shown in Figs. 3 and 4. To simplify operation of the dynamic voltage balancing, voltage-dividing resistors are omitted and two series-connected IGBTs are considered. It is assumed that  $C_a$  and  $C_c$  are charged with  $V_s/2$  and are much bigger (about ten times) than  $C_b$  and  $C_d$ . Therefore,  $C_a$  and  $C_c$  are considered here as constant voltage sources,  $V_s/2$  and the switch  $S_2$  is turned on earlier and turned off later than  $S_1$  for any reason.  $GD_1$  and  $GD_2$  are basic gate drive signals. The proposed circuit has six operating modes within each switching period.

Mode 1:  $S_1$  and  $S_2$  are turned on, the gate voltages of  $GD_1$  and  $GD_2$  are high. Because the voltage of  $C_a$  and  $C_c$  is  $V_s/2$ , the voltages of  $C_b$  and  $C_d$  are charged with  $-V_s/2$ . Diodes  $D_a$  and  $D_b$  block the reverse voltage of  $V_{cb}$  and  $V_{cd}$ .

Mode 2: The gate drivers of S1 and S2 go off but the gate driver of S2 is off a little bit earlier. The switch current is decreasing gradually and, at the same time, the switch voltage of S2 starts increasing first and that of S1 follows.  $C_b$  and  $C_d$  are charged up from  $-V_s/2$ . The voltage of S2 is increased more rapidly than that of S1 and reaches the steady-state value  $V_s/2$  first. The voltage of  $C_d$  also reaches zero first.

Mode 3: Since the voltage of S1 is still lower than  $V_s/2$ , both voltages of S1 and S2 are continually increased, and then the voltage of S2 is increased to more than  $V_s/2$ . At the same time, the voltage of  $C_d$  goes positive, and this voltage is applied to the gate terminal of S2 through D2 and  $R_{g2}$  resulting in slightly turning on of S2. Therefore, the rising voltage of S2 is decreased sharply, and then the voltage of  $C_d$  is also decreased trying to turn off of S2 again. At the end of this mode, the voltage of S1 reaches  $V_s/2$  and then all switches are well balanced.

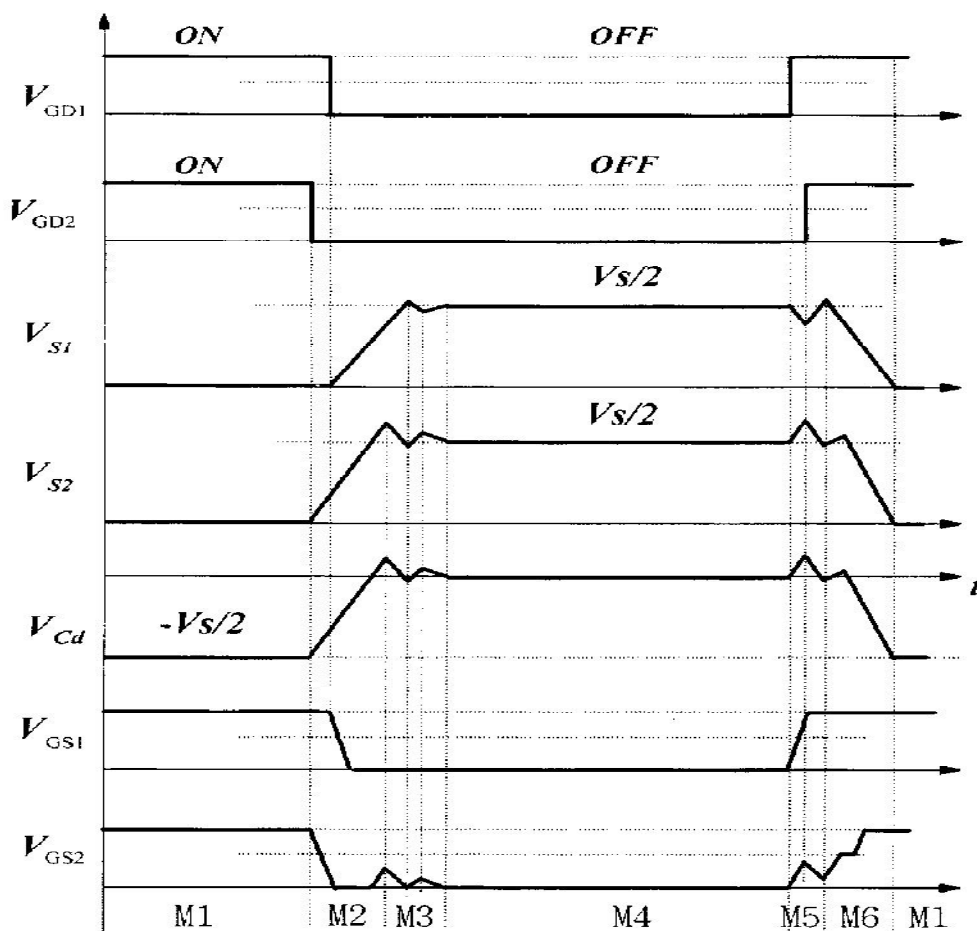

Fig. 4. Operational waveform

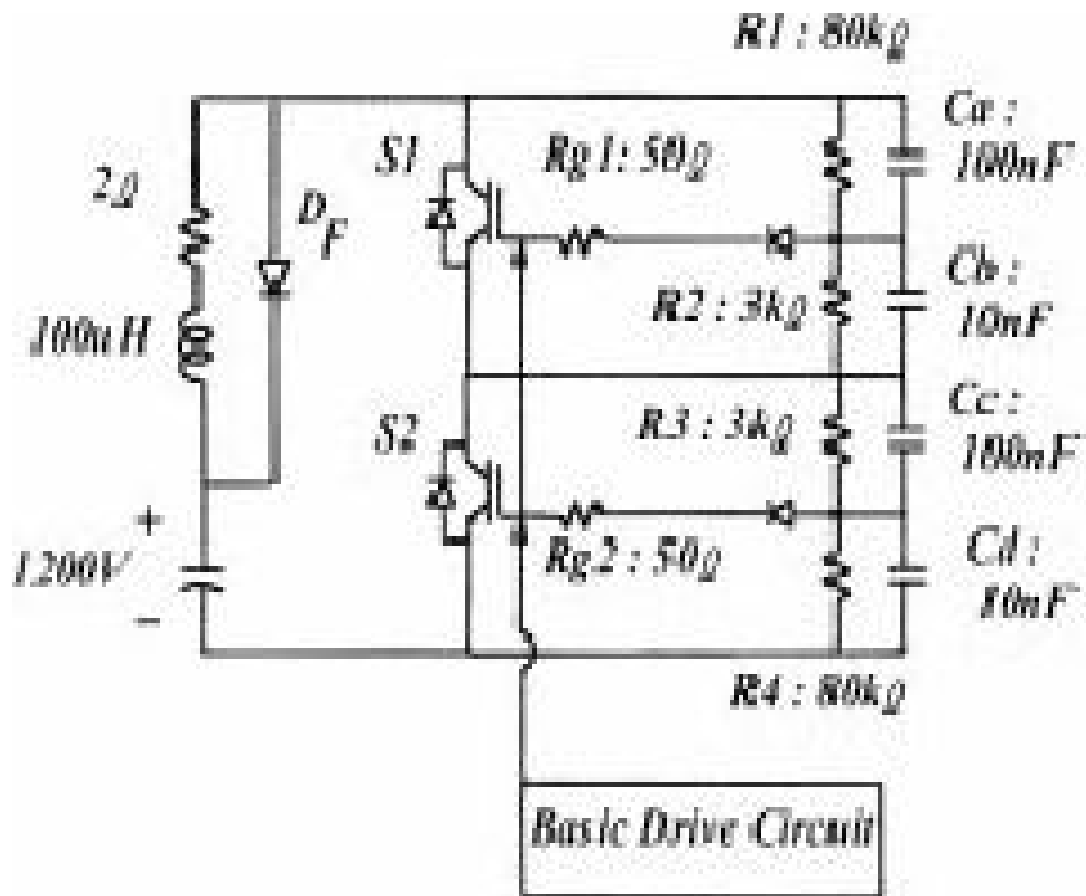

Fig. 5. Simulation circuit

Mode 4: The switch  $S_1$  and  $S_2$  are turned off with the balanced voltage  $V_s/2$ . Load current freewheels through the diode.

Mode 5: Now, the gate driver of  $S_1$  is on first and that of  $S_2$  follows a little bit later. When  $S_1$  starts turning on, the overvoltage is applied to switch  $S_2$ . Then, the voltage of  $C_d$  is increased to positive as that of Mode 3, which turns on  $S_2$  slightly and reduces the voltage of  $S_2$ . Both voltages of  $S_1$  and  $S_2$  reach zero at the end of this mode.

Mode 6: Both switches are turned on completely. The  $C_b$  and  $C_d$  are charged to  $-V_s/2$ , again. This is the end of one switching cycle. The dynamic voltage balancing is achieved at any condition of layouts, devices, and gate drivers.



**IV. FEATURES OF THE PROPOSED CONVERTER: A. Automatic Voltage Balancing**

The static voltage balancing is simply achieved by the voltage-dividing resistors, as in the other balancing techniques[1]–[5]. The dynamic voltage balancing is automatically achieved by the action of the simple auxiliary circuit. The switch voltage fed back through - - ( -D2- ), which slightly turns on the switch again, limiting the switch voltage with the normal voltage. This action is just like the active voltage clamping. Therefore, the auxiliary circuit provides the dynamic voltage balancing at any condition, including unequal device switching characteristics, unequal stray inductance, unequal gate drive delay time, etc. Neither additional control circuit nor special gate drive is necessary. There is no additional switching loss, either. The number of devices to be connected is not limited

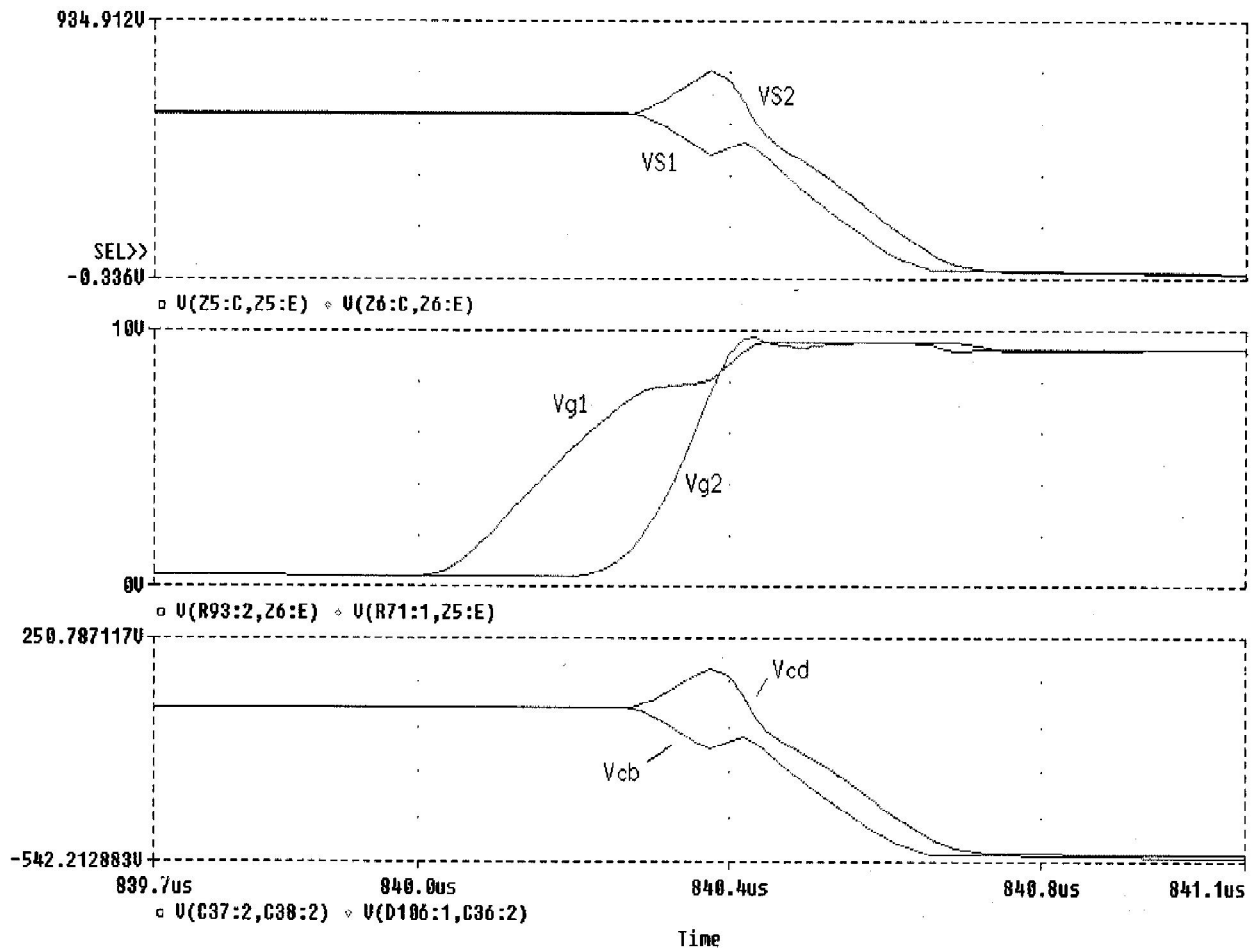

( a )

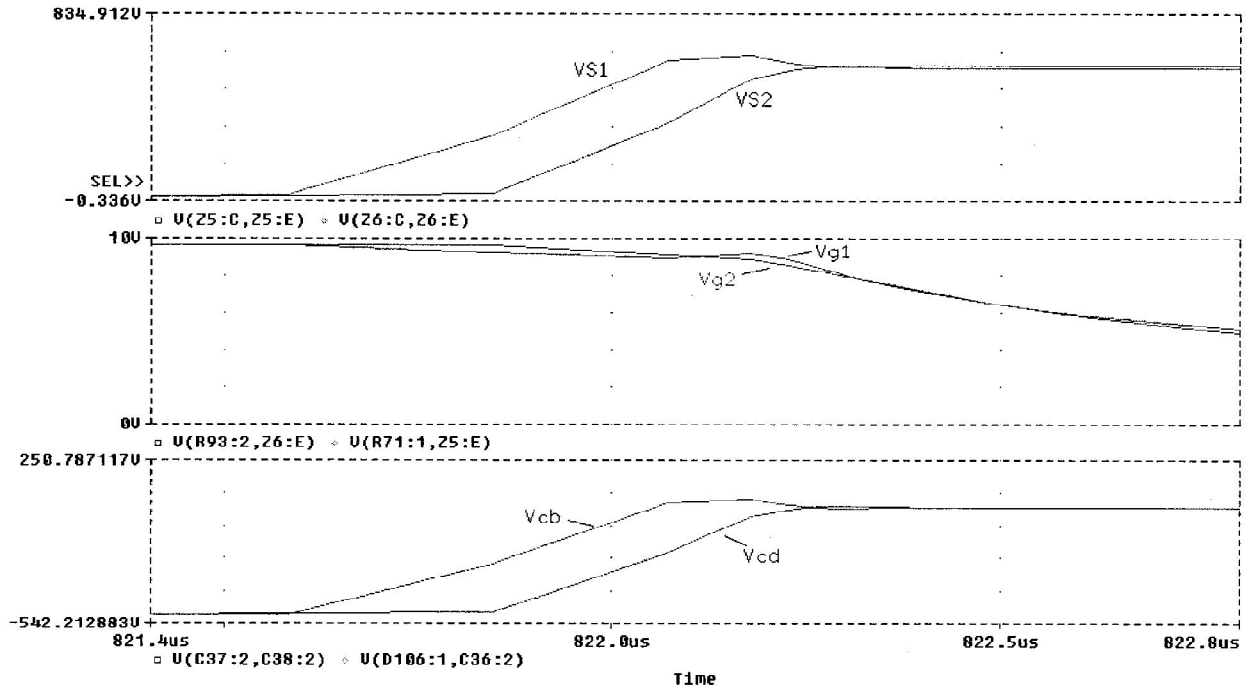

(b)

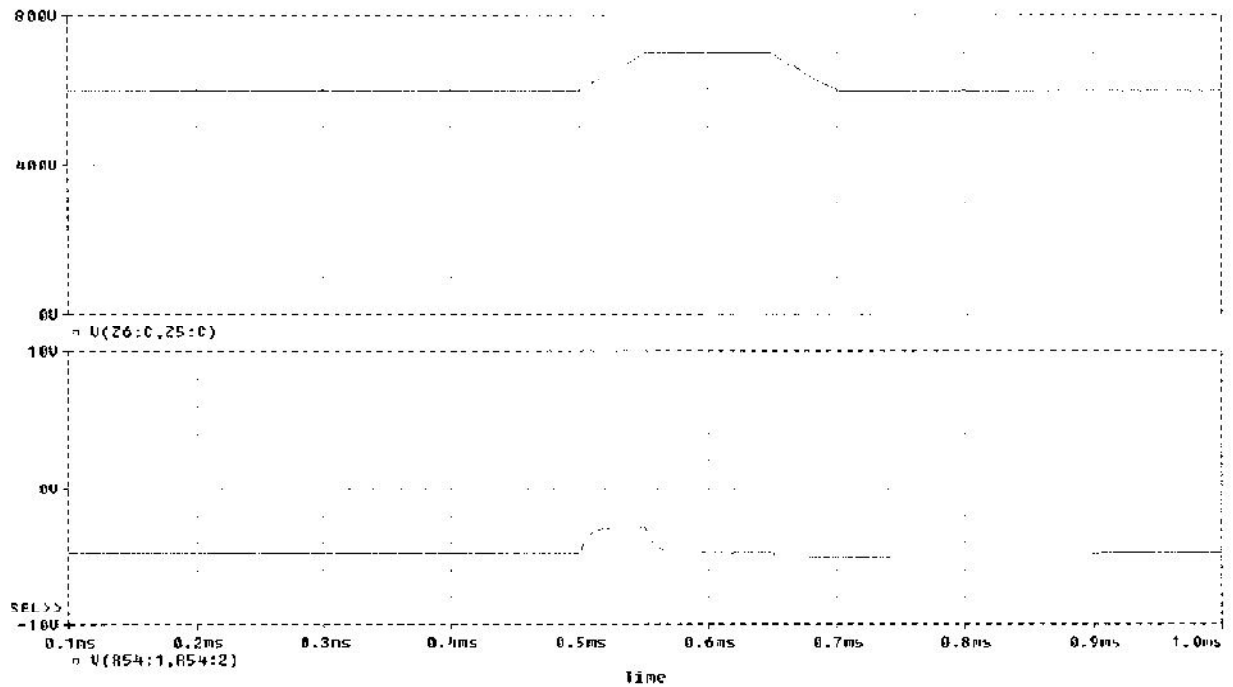

Fig. 7. Simulated waveforms when the dc-link voltage is abruptly changed(top: dc-link voltage; bottom: gate voltage).

### **B. Simple and Low Loss:**

The auxiliary circuit consists of all passive components and all small power ratings compared to the main devices. The loss involved with the auxiliary circuit is almost negligible. Therefore, the proposed technique is a very efficient, reliable, and economic solution.

## **V. DESIGN CONSIDERATIONS:**

### **A. Decision of Capacitors**

To detect the overvoltage, the voltage of capacitor  $C_a$  ( $C_c$ ) has to be almost constant during a short switching period. Therefore,  $C_a$  ( $C_c$ ) should be much bigger than capacitor  $C_b$  ( $C_d$ ). The empirical range of  $C_a$  ( $C_c$ ) is about 100 nF. The  $C_b$  ( $C_d$ ) is charged and discharged repeatedly at every switching period. In order to get proper operation and to reduce loss,  $C_b$  ( $C_d$ ) should be much smaller, although it depends on the switching frequency. At several kilohertz switching frequency range, 10% of  $C_a$  ( $C_c$ ) is enough for  $C_b$  ( $C_d$ ).

### **B. Design of Resistors**

If the voltage-dividing resistors are too small, the static balancing is well achieved, but the loss is increased. If the resistor are too big, the static balancing will fail. Therefore, the voltage-dividing resistors should be designed by considering the leakage current of devices and loss. The gate resistor  $R_{g1}$  ( $R_{g2}$ ) should also be designed carefully. The device voltage is fed back to the gate through  $C_a$  ( $C_c$ ) and  $R_{g1}$  ( $R_{g2}$ ), which provides the dynamic voltage balancing. The feedback effect is not so sensitive with  $R_{g1}$  ( $R_{g2}$ ), but the dynamic voltage balancing is not properly achieved if  $R_{g1}$  ( $R_{g2}$ ) is too high or too low. (If  $R_{g1}$  ( $R_{g2}$ ) is too high, the feedback effect is reduced and so is the voltage balancing or vice versa.) The empirical range of  $R_{g1}$  ( $R_{g2}$ ) is about ten times that of  $R_{gg1}$  ( $R_{gg2}$ ).

### C. DC-Link Voltage Variation

$C_a$  ( $C_c$ ) is constantly charged with the voltage of  $V_s/2$  and  $C_b$  ( $C_d$ ) is charged with  $-V_s/2$  and discharged to zero according to the switching state. If the dc-link voltage is increased, the voltage of  $C_a$  ( $C_c$ ) should be increased to allow proper operation. The main charging path of  $C_a$  and  $C_b$  is the  $R_g$  and the gate-emitter junction during the turn-off state of switches. If the dc-link voltage is increased abruptly, the voltage of  $C_b$  ( $C_d$ ) can be positive and switches  $S_1$  and  $S_2$  can be turned on without the turn-on gate signal, resulting in undesirable operation. Therefore, the dc-link voltage should not be changed abruptly. This effect, however, can normally be ignored since the dc-link capacitance is usually very high and the voltage is changed very slowly.

## VI. SIMULATION RESULTS

To verify the operation of the proposed circuit, an example circuit, two series-connected IGBTs, is designed as shown in Fig. 5 and simulated using PSPICE. To give an intentional difference in switching conditions, the gating signal of  $S_2$  is delayed 0.2  $\mu$ s. Fig. 6 shows the simulated waveforms during turn-on and turn-off transients. The feedback through auxiliary circuits is shown in Fig. 6. During turn-on transient, the gating signal of  $S_1$  is applied first and the voltage of  $S_1$  starts decreasing, as shown in Fig. 6(a). This means that the voltage of  $S_2$  is increasing over the steady-state voltage  $V_s/2$ . This overvoltage charges  $C_d$  and applies a positive voltage to the gate of  $S_2$  and, thus,  $S_2$  is turned on slightly, even though the real gating signal of  $S_2$  is not yet applied. Therefore, the dynamic voltage balancing is achieved during the turn-on transient. During the turn-off transient,  $S_1$  is turned off first and the voltage of  $S_1$  is increased and reaches  $V_s/2$  first. If  $V_{s1}$  is increased over the steady-state voltage  $V_s/2$ , a positive voltage is applied to the gate of  $S_1$  and the voltage of  $S_1$  is decreased and stays at  $V_s/2$  until the voltage of  $S_2$  reaches  $V_s/2$ , as shown in Fig. 6(b). Therefore, the dynamic voltage balancing is also achieved at the turn-off transient.

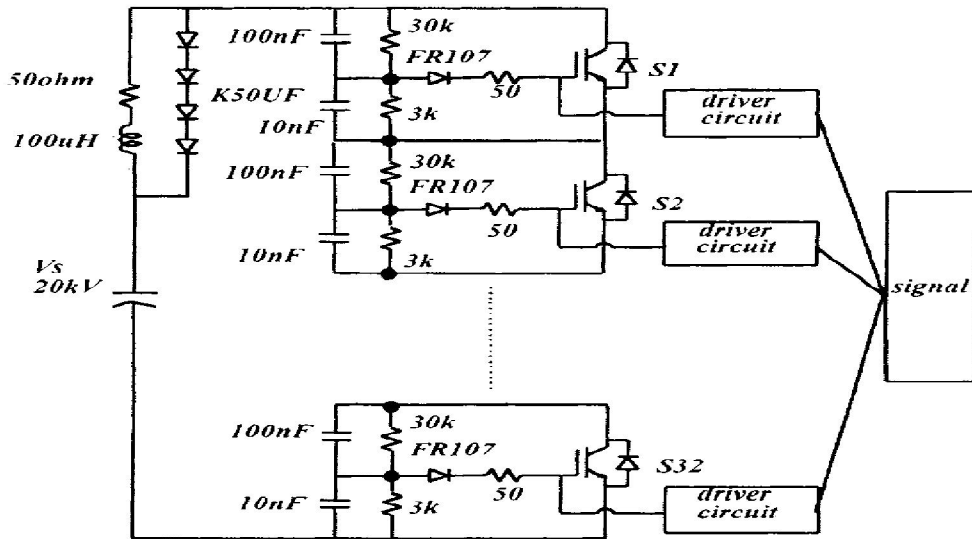

Fig. 8. Experimental circuit diagram for series operation of 16 IGBTs.

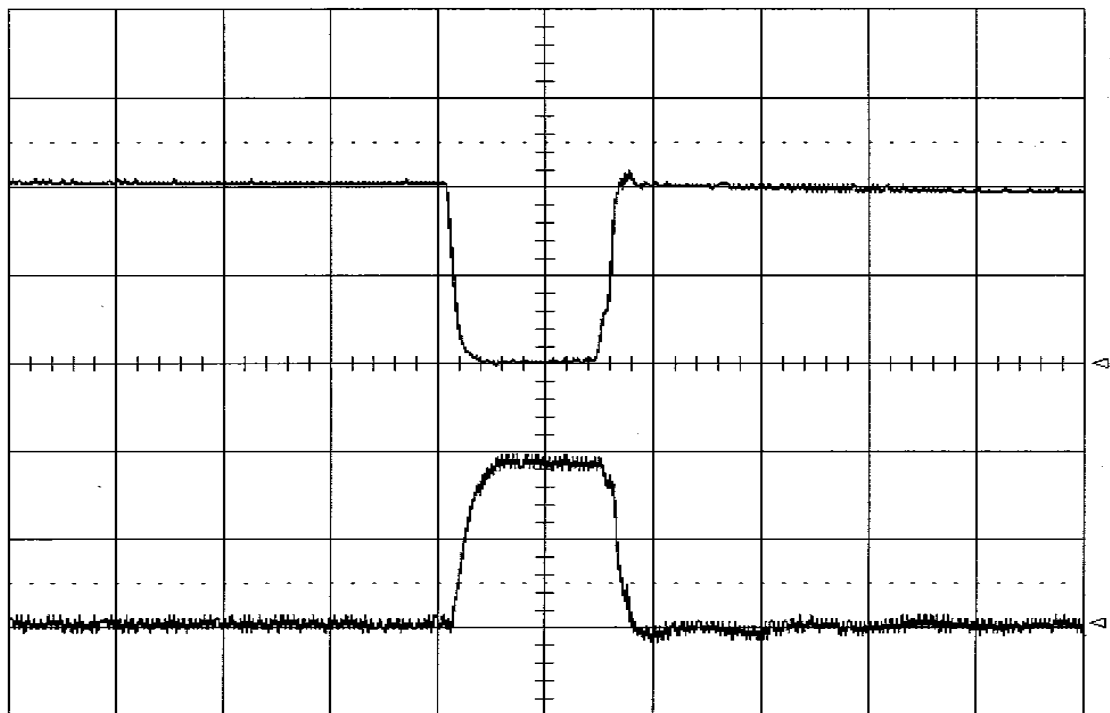
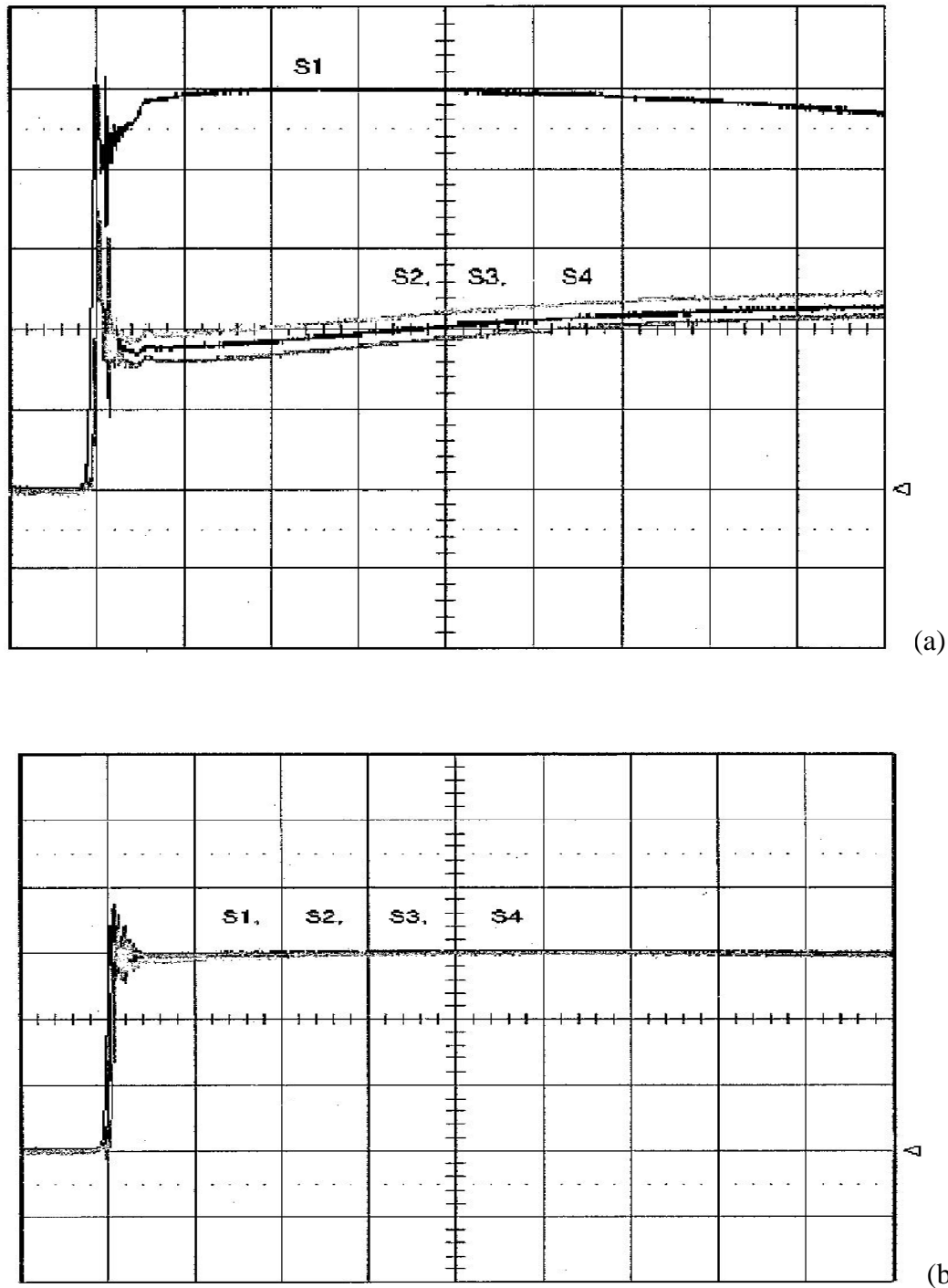

Fig. 9. Voltage and current waveforms of series-connected switches. Top: voltage (10 kV/div); bottom: current (200 A/div). Time (5 s/div).

Fig. 7 shows the simulated waveforms when the dc-link voltage is abruptly changed to see the effect of dc-link voltage variation in the turn-off steady state. With a 100-V rise of dc-link voltage in 50 s, the gate voltage is a little increased but remains under the threshold voltage.

Therefore, the unwanted turn-on effect of IGBTs does not occur, unless the dc-link voltage is not changed too abruptly.

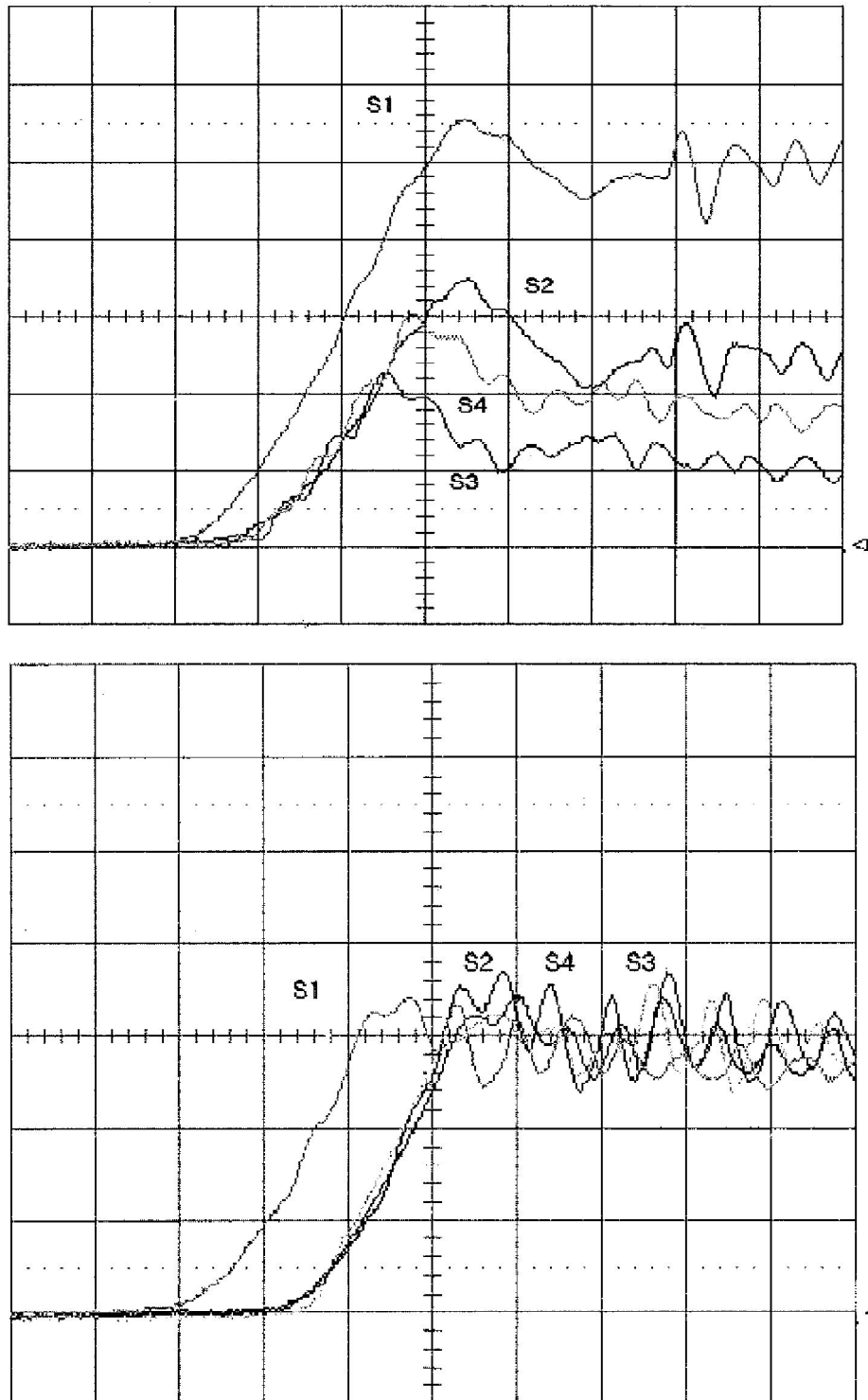

**Fig. 10. Voltage waveforms of switches during turn-off transient. (a) Without auxiliary circuit. (b) With auxiliary circuit. Voltage (200 V/div). Time (5 s/div).**

## VII. EXPERIMENTAL RESULTS

To verify the operation of the proposed circuit, a 20-kV 400-A single-pole switching circuit has been built and tested. Fig. 8 shows the experimental circuit diagram with the parts numbers of the components used. Sixteen IGBT modules (1200 V/400 A, SKM400GB124D from Semikron) are series connected with the proposed auxiliary circuit. As a load  $R = 50\text{ohms}$ , and  $L = 100\mu\text{H}$  are used. All gate drivers have the same characteristics except those of S1. S1 is turned on a little bit later and turned off a little bit earlier than the others to give an intentional difference in switching conditions.

Fig. 9 shows the voltage and current waveforms of the switches connected in series. It can be seen that the switching waveforms are clean. just like the waveforms of a single-switch circuit, thanks to the voltage-balancing function of the proposed auxiliary circuit. Fig. 10 shows the voltage waveforms of four interesting switches during the turn-off transient period with and without the auxiliary circuit, and Fig. 11 shows the extended waveforms of Fig. 10. As shown in Figs. 10(a) and 11(a), there exists a big imbalance among the switch voltages since the auxiliary circuits are not included. The voltage of S1 is increased much higher than the others since S1 is turned off early. In addition, the other voltages of the switches are not the same, either due to small differences of characteristics and stray inductances among devices. The transient voltages of switches when the auxiliary circuits are included are almost the same, even though S1 is turned off early, thanks to the balancing action of the auxiliary circuit. The dynamic voltage balancing is done well. Fig. 12 shows the voltage waveforms of switches during the turn-on transient. When the auxiliary circuits are not included, there exists a high voltage peak across S1 since S1 is turned on later. When the auxiliary circuits are included, however, there is no voltage peak, as shown in Fig. 12(b). The voltage imbalance of switches is less than 15% during the turn-off transient and less than 5% during the turn-on transient. The dynamic voltage balancing is performed well for both turn-on and turn-off transients since 20% of voltage imbalance is usually acceptable. Fig. 13 is a photograph of the IGBT stack with gate drivers.



**Fig. 11. Extended waveforms of Fig. 10. (a) Without auxiliary circuit. (b) With auxiliary circuit. Voltage (200 V/div). Time (0.2 s/div).**



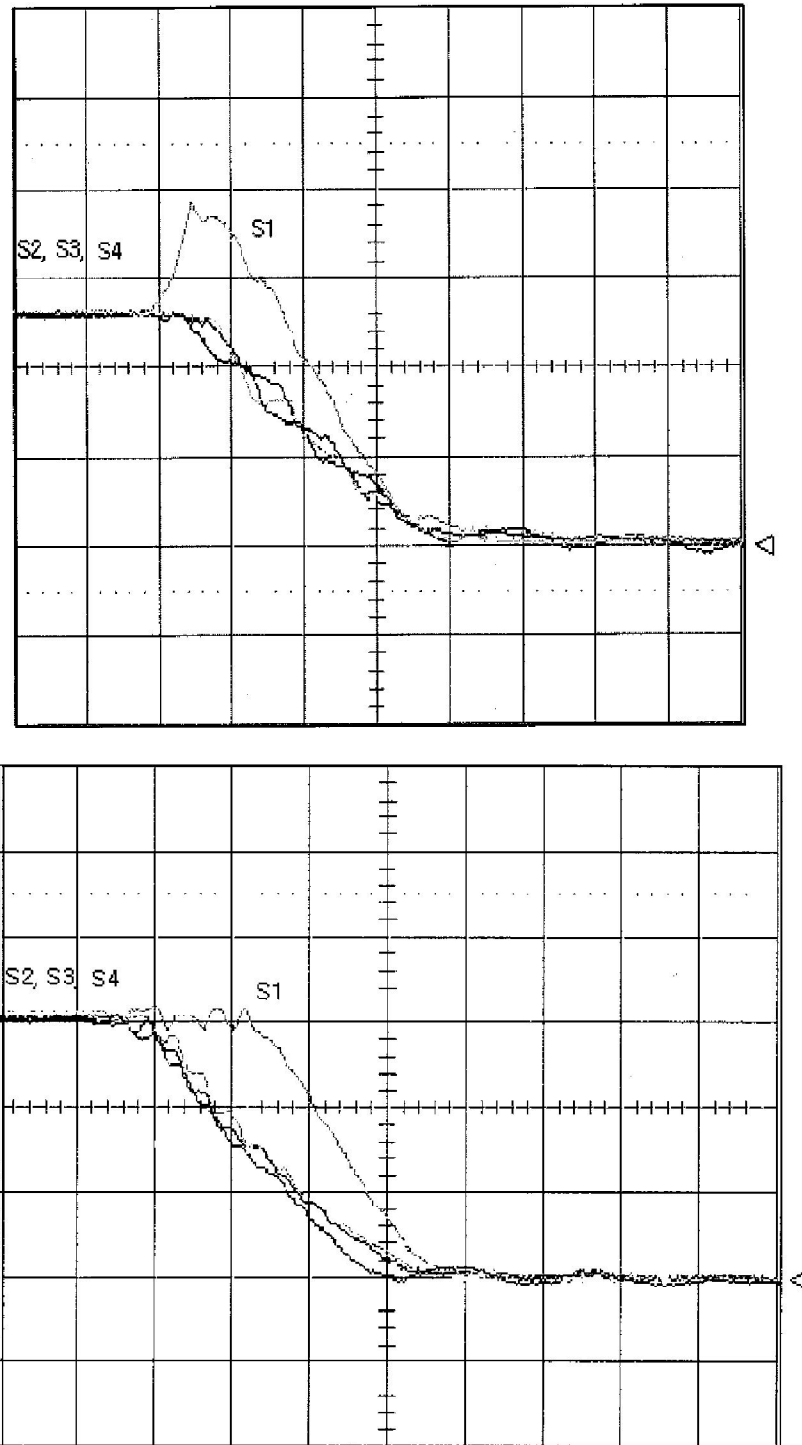

**Fig. 12. Voltage waveforms of switches during turn-on transient. (a) Without auxiliary circuit. (b) With auxiliary circuit. Voltage (200 V/div). Time (0.2 $\mu$ s/div).**



**Fig. 13. Photograph of the series-stacked IGBTs with gate drivers.**

### **VIII. CONCLUSION**

A novel technique for series operation of IGBTs was presented. The operation, analysis, features, and design considerations were illustrated and verified by the experimental results on a 20-kV/400-A prototype with 16 series-connected IGBTs. It has been shown that the dynamic voltage balancing as well as the static balancing are well achieved with the proposed auxiliary circuit. The proposed technique has many distinctive advantages over those previously presented, as follows:

- simple and low cost;
- high reliability;
- extendibility (unlimited number);
- no additional loss.

These advantages make the proposed technique very promising for high-voltage high-power applications.